

Altivar 61

User's manual

Retain for future use

Pump switching card

VW3 A3 502

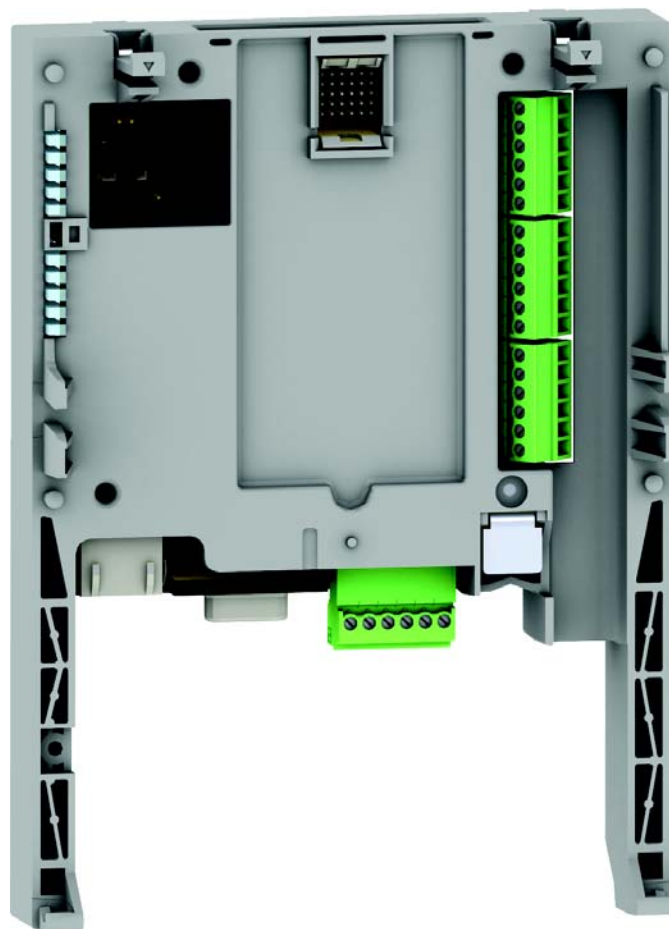

Contents

Important information	4
Before you begin	5
Documentation structure	6
Description	7
Description of the terminals	8
Characteristics	9
Data backup battery	10
Operating Principle	11
General	11
Choosing a variable speed pump	12
Choosing an auxiliary pump (fixed speed)	12
Operation using limited relative operating time	12
Special cases	12
Selecting the operating mode	13
Controlling an auxiliary pump	13
"Sleep" function/"Wake up" function	13
Compensation for loss of head	14
Menus - Parameter Setting	15
Using the graphic display terminal or the setup software, in "connected to drive" mode	15
[1.14 Multi pump] (SPL-) menu	15
Parameters in the [1.14 Multi pump] (SPL-) menu	17
Architecture of the booster station	19
Connection diagrams	20
Setup	23

Important information

PLEASE NOTE

Please read these instructions carefully and examine the device in order to familiarize yourself with it before installation, operation or maintenance. The specific messages which follow can appear in the documentation or on the device. They warn you of potential dangers or draw your attention to information which can clarify or simplify a procedure.



The presence of this symbol on a danger or warning label indicates that there is a risk of electrocution, which can cause bodily injury if the instructions are not followed.



This is the symbol for a safety warning. It warns you of a potential danger of bodily injury. Follow all the safety instructions accompanying this symbol to avoid any situation that can result in injury or death.

DANGER

DANGER indicates a dangerous situation **resulting in** death, serious injury or equipment damage.

WARNING

WARNING indicates a situation involving risks that can **cause** death, serious injury or equipment damage.

CAUTION

CAUTION indicates a potentially dangerous situation that can **result in** bodily injury or equipment damage.

IMPORTANT NOTE

The maintenance of electrical equipment must only be performed by qualified personnel. Schneider Electric can in no way be held responsible for the consequences of using this documentation. This document is not intended to be used as a guide by persons who have received no training.

© 2005 Schneider Electric. All rights reserved.

Before you begin

Read and understand these instructions before performing any procedure on this drive.

DANGER

RISK OF DANGEROUS VOLTAGE

- Read and understand this manual in full before installing or operating the variable speed drive. Installation, adjustment, repair, and maintenance must be performed by qualified personnel.
- The user is responsible for compliance with all international and national electrical standards in force concerning protective grounding of all equipment.
- Many parts of this variable speed drive, including the printed circuit boards, operate at the line voltage. DO NOT TOUCH. Use only electrically insulated tools.
- DO NOT touch unshielded components or terminal strip screw connections with voltage present.
- DO NOT short across terminals PA and PC or across the DC bus capacitors.
- Install and close all the covers before applying power or starting and stopping the drive.
- Before servicing the variable speed drive
 - Disconnect all power.
 - Place a "DO NOT TURN ON" label on the variable speed drive disconnect.
 - Lock the disconnect in the open position.
- Disconnect all power including external control power that may be present before servicing the drive. Wait for the charging LED to go off. WAIT 15 MINUTES for the DC bus capacitors to discharge. Then follow the procedure for measuring the DC bus voltage given in the Installation Manual. The drive LEDs are not accurate indicators of the absence of DC bus voltage.

Failure to follow these instructions will result in death, serious injury or equipment damage.

CAUTION

DAMAGED EQUIPMENT

Do not install or operate any drive that appears damaged.

Failure to follow this instruction can result in bodily injury and/or equipment damage.

Documentation structure

Installation Manual

This manual describes:

- How to assemble the drive
- How to connect the drive

Programming manual

This manual describes:

- The functions
- The parameters
- Use of the drive terminal (integrated display terminal and graphic display terminal).

Communication Parameters Manual

This manual describes:

- The drive parameters with specific information (addresses, formats, etc.) for use via a bus or communication network
- The operating modes specific to communication (state chart)
- The interaction between communication and local control

Communication bus and network manuals (Modbus, CANopen, Ethernet, Profibus, INTERBUS, DeviceNet, etc.)

These manuals describe:

- Connection to the bus or network
- Configuration of the parameters specific to communication via the integrated display terminal or the graphic display terminal
- Diagnostics
- Software setup
- The protocol communication services

Altivar 38 compatibility manual

This manual describes the differences between the Altivar 61 and the Altivar 38.

It explains how to replace an Altivar 38, including how to replace drives communicating on a bus or network.

Description

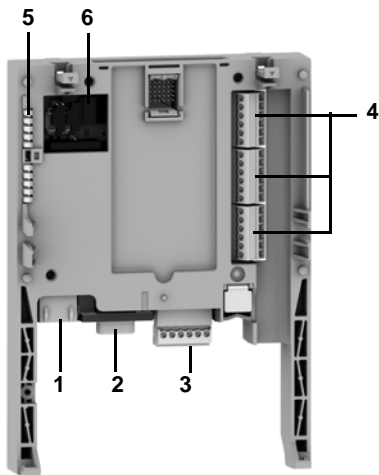

- 1 RJ45 connector (not used)
- 2 9-way male SUB-D connector for connection to the CANopen bus (not used)
- 3 Connector with removable screw terminals, 6 contacts at intervals of 3.81 for the 24 V --- power supply and 4 logic inputs.
- 4 3 connectors with removable screw terminals, 6 contacts at intervals of 3.81 for 6 logic inputs, 6 logic outputs, 2 analog inputs, 2 analog outputs and 2 commons. Some inputs and outputs are not used, as detailed on the next page.
- 5 5 LEDs, comprising:
 - 1 to indicate the presence of the 24 V --- power supply
 - 1 to indicate a program execution fault
 - 2 to indicate the CANopen bus communication status
 - 1 controlled by the application program.
- 6 Block of 4 configuration switches (not used)

Hardware setup

Description of the terminals

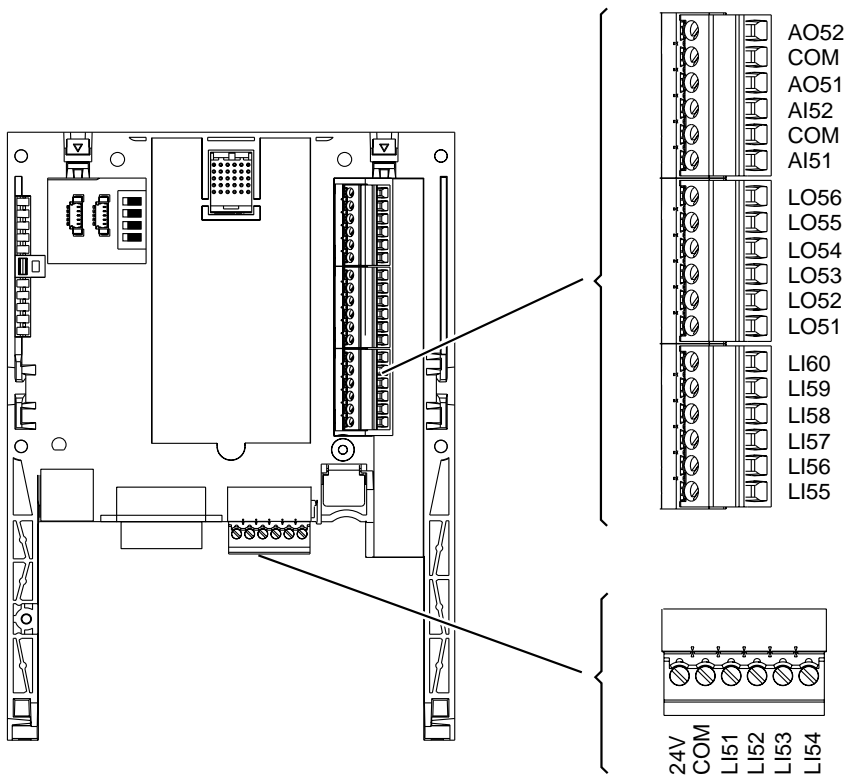

Terminals	Function
24V	<p>Power supply for the pump switching card, logic outputs and analog outputs.</p> <p>If allowed by the power consumption table (for example if outputs are not being used), the pump switching card can be powered by the 24 V --- power supply in the drive.</p> <p>If you are using an external power supply:</p> <ul style="list-style-type: none"> The pump switching card must be turned on before the drive is turned on, or at the same time as the drive is turned on. <p>If this order is not followed, the drive will lock in a card fault (ILF). This fault cannot be reset, and the only way to acknowledge it is to turn off the drive.</p> <ul style="list-style-type: none"> Catalog number for a Telemecanique power supply (24 V ---, 2A): ABL7 RE 24 02.
COM (3 terminals)	<p>Common ground and electrical 0V of the pump switching card power supply, logic inputs, (LI●●), outputs (LO●●), analog inputs (AI●●) and analog outputs (AO●●).</p> <p>This ground and electrical 0V are common with the drive ground and electrical 0V. There is therefore no point in connecting this terminal to the 0V terminal on the drive control terminals.</p>
LI51 to LI60	<p>24 V --- logic inputs</p> <p>LI56 to LI60 = Not used</p>
LO51 to LO56	<p>24 V --- logic outputs</p> <p>LO56 = Not used</p>
AI51 and AI52	<p>0 ... 20mA analog inputs</p> <p>Not used</p>
AO51 and AO52	<p>0 ... 20mA analog outputs</p> <p>Not used</p>

Hardware setup

Characteristics

Electrical characteristics

Power supply	Voltage	V	24 \pm (min. 19, max. 30)
Current consumption	Maximum	A	2
	No-load	mA	80
	Using logic output	mA	200 maximum (1)
Logic inputs	LI51...LI60		Impedance 4.4 k Ω Maximum voltage: 30 V \pm Switching thresholds: State 0 if ≤ 5 V or logic input not wired State 1 if ≥ 11 V Common point for all the card I/O (2)
Logic outputs	LO51...LO56		Six 24 V \pm logic outputs, positive logic open collector type (source), compatible with level 1 PLC, standard IEC 65A-68 Maximum switching voltage: 30 V Maximum current: 200 mA Common point for all the card I/O (2)
I/O connection	Type of contact		Screw, at intervals of 3.81 mm ²
	Maximum capacity	mm²	1.5 (AWG 16)
	Tightening torque	Nm	0.25
Lithium battery	Life		8 years

 (1) If the power consumption table does not exceed 200 mA, this card can be powered by the drive. Otherwise, an external 24 V \pm power supply must be used.
(2) This common point is also the drive 0 V (COM).

Hardware setup

Data backup battery

The pump switching card has a non-volatile RAM (NVRAM) which is needed to store variables. A lithium battery is mounted on this non-volatile RAM to avoid this data being lost when the card is turned off.

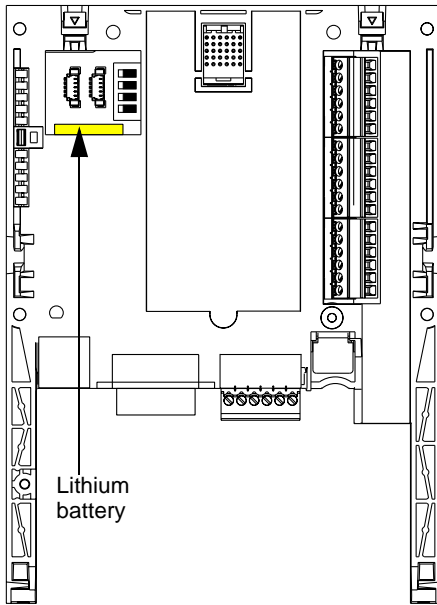

When installing the pump switching card in the drive, make sure that this battery is present. It takes the form of a rectangular block clipped onto the non-volatile RAM (see schematic opposite).

The battery life is 8 years.

The battery has a realtime clock for timestamping faults.

The date and time on this clock are checked and set from a special sub-menu in the [\[1.14 - Multi pump\] \(SLE-\)](#) customizable menu in the graphic display terminal.

The date and time need to be set on receipt of the pump switching card, or after replacing its lithium battery.

The lithium battery must only be replaced when the drive and the pump switching card are turned off.

During this operation, the data saved in the NVRAM (4 Kwords) is lost.

Operating Principle

General

The main object is to control a complete pumping installation using a single ATV61 drive, providing:

- Constant pressure in the system whatever the flow rate
- A simple method for setting up and diagnosing the installation via the ATV61.

The system is operated using several fixed speed pumps (maximum of 4), and one variable speed pump, which is unable to provide the full flow range required on its own. A PI regulator is used for pump control. The pressure sensor provides system feedback. To avoid systematic wear of the same pumps, a function is provided that allows switching of the pumps according to their operating time. The variable pump can also be included in this changeover procedure.

The variable speed pump (**PV**) is called a **variable** pump.
The fixed speed pumps are called **auxiliary** pumps.

Application example with 3 fixed pumps:

The auxiliary pumps are turned on and off according to the flow rate required by the installation. The variable pump is controlled so as to ensure continuity in the flow rate variations.

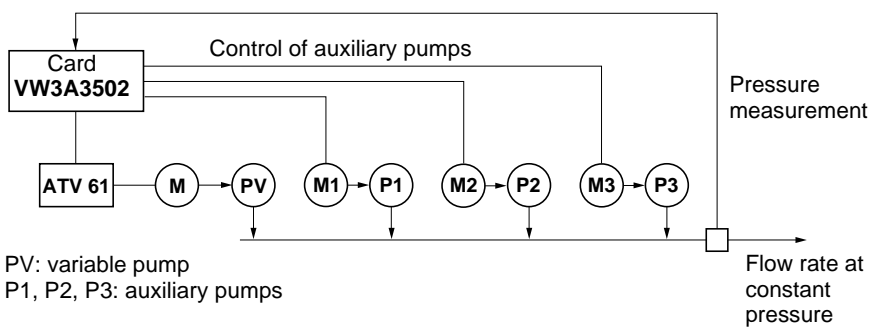

PV: variable pump
P1, P2, P3: auxiliary pumps

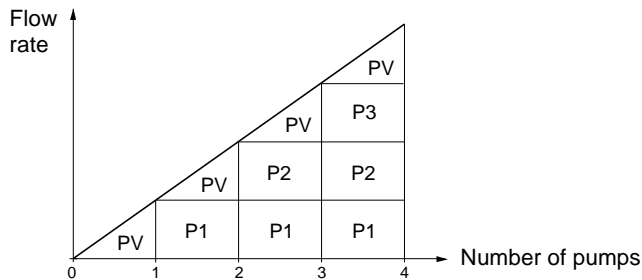

Operating Principle

The Altivar 61 controls the pumps via logic outputs LO51, LO52, LO53, etc., according to the operating mode that has been programmed.

The logic inputs indicate the state of the pumps to the Altivar 61:

- LI = 1, the pump is ready to operate
- LI = 0, the pump is faulty

Hour counters are used to determine the total operating time of each pump.

Choosing a variable speed pump

Single variable

In this mode, the same variable pump is always used. It is always controlled by the drive.

Multiple variable

In this mode, all the pumps can be variable (one at a time). The variable pump is chosen according to its operating time stored by the Altivar 61: the pump with the shortest operating time is selected. The variable pump can only be changed over if all the auxiliary pumps are off.

Choosing an auxiliary pump (fixed speed)

2 options:

- The auxiliary pumps are started in ascending order of the logic outputs (example: LO51, then LO52, then LO53, then LO54, then LO55). The auxiliary pumps are stopped in descending order of the logic outputs (example: LO55, then LO54, then LO53, then LO52, then LO51)
- **Switching the auxiliary pumps**
Starting up an auxiliary pump: the pump with the shortest operating time stored in the drive is selected.
Stopping an auxiliary pump: the pump with the longest operating time stored in the drive is selected.

Operation using limited relative operating time

A relative operating time differential between each pump can be programmed to ensure better distribution of operating times, thereby limiting pump wear. If the total operating time differential between an operating auxiliary pump and one which is off exceeds the programmed differential, the first pump is stopped and replaced by the second one.

The variable pump can only be replaced if all the auxiliary pumps are off, and if its operating frequency is below the programmed threshold **[V.pumpSwFr] (O18)**.

Special cases

If a pump is shown as "faulty" (LI=0), it is not taken into account by the Altivar 61 and the starting and stopping conditions apply only to the other pumps.

Operating Principle

Selecting the operating mode

The pump switching card provides 9 possible operating modes. These modes combine: the choice of variable pump, the choice of auxiliary pump and limitation of relative operating time.

The mode is selected using the **[Op. mode] (O01)** parameter, (**[1.14 Multi pump] (SPL-)** menu).

Controlling an auxiliary pump

The PI regulator output (frequency reference of the variable pump) is used to control starting or stopping of an auxiliary pump with hysteresis, as shown in the figure below:

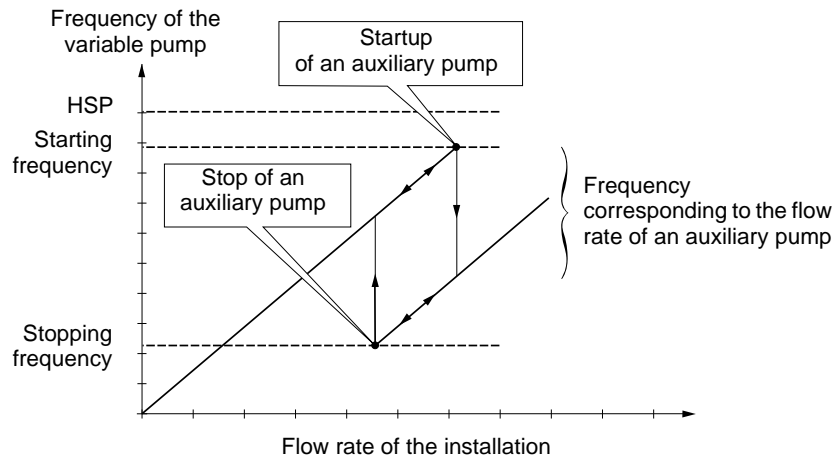

When the frequency exceeds the starting threshold (**[FrqAuxPumpOn] (O12)** parameter), a time delay (**[Pump Delay On] (O03)** parameter) is started to avoid the effects of transient flow fluctuations. If after this time delay, the frequency remains higher than the starting threshold, another pump is started. When the start command is sent, a time delay (**[Acc Aux Pump] (O06)** parameter) is started to allow the pump to reach its nominal speed before starting another pump (avoids oscillation).

When the frequency is below the stopping threshold (**[FrqAuxPumpOff] (O13)** parameter), a time delay is started (**[Pump Delay Off] (O04)** parameter) to avoid the effects of transient flow fluctuations. If after this time delay, the frequency remains below the stopping threshold, a pump is stopped. When the stop command is sent, a time delay (**[Dec Aux Pump] (O07)** parameter) is started to allow the pump to reach an effective stop before stopping another pump (avoids oscillation).

"Sleep" function/"Wake up" function

This function is used to stop the variable pump when the flow rate is zero (all the auxiliary pumps are off).

In this case, if the frequency of the variable pump is below the "sleep" threshold (**[Sleep thresh] (O15)** parameter), a time delay (**[SleepFunctDel] (O05)** parameter) is started. If, after this time delay **[SleepFunctDel] (O05)**, the frequency remains below the **[Sleep thresh] (O15)** threshold, the variable pump then stops. The installation is in "sleep" state.

To switch to "wake up" state, the pressure feedback must drop to below the "wake up" threshold (**[WUp thresh] (O16)** parameter). The variable pump is then started.

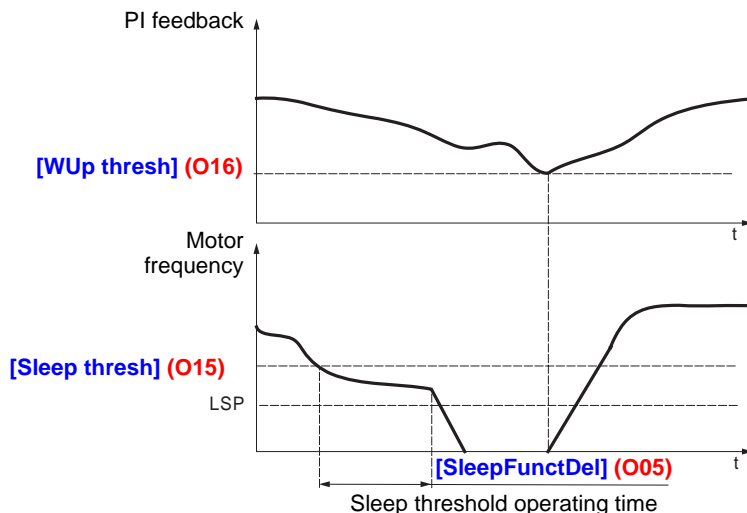

Operating Principle

Compensation for loss of head

An additional step [Pr adj coeff] (O14) is automatically added to the reference value each time an auxiliary pump is started. These reference steps compensate for a loss of pressure (loss of head) in the pipework due to an increase in flow rate.

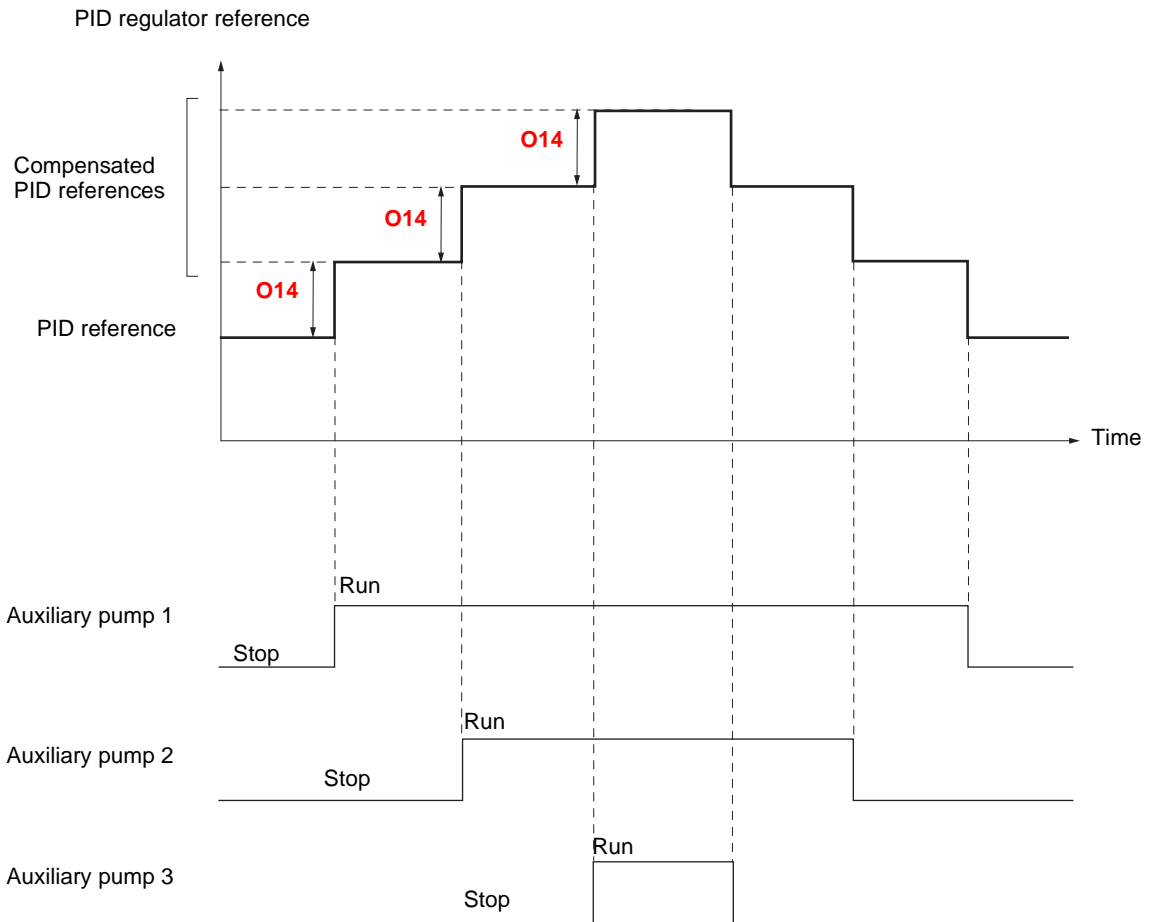

- Compensation for loss of head is active when the [Pr adj coeff] (O14) parameter is other than 0.
- The new PID regulator reference is generated using "PID preset reference 2" [Preset ref. PID 2] (rP2).

 The [Preset ref. PID 2] (rP2) parameter is controlled by the pump switching card. It is therefore not possible to use the "PID preset references" function with the "Compensation for loss of head" function.

Example of using the PID regulator with an internal reference:

- [Internal PID ref.] (rPI) = 400 (internal reference)
- [Min PID feedback] (PIF1) = 200
- [Max PID feedback] (PIF2) = 1000
- [Pr adj coeff] (O14) = 50

Each time an auxiliary pump is started the reference becomes:

- variable pump + 1 auxiliary pump: new reference = 450
- variable pump + 2 auxiliary pumps: new reference = 500
- variable pump + 3 auxiliary pumps: new reference = 550

Menus - Parameter Setting

The various menus, the configuration, the settings and file transfers are accessed in the same way as with the standard drive using the information given in the Programming Manuals, with the addition of the following special features:

Using the graphic display terminal or the setup software, in "connected to drive" mode

If the VW3 A3502 card is present in the drive, some of the drive parameters which are necessary for the specific functions of the card are automatically preconfigured. It also brings up a new **[1.14 Multi pump] (SPL-)** menu with new specific parameters to be configured. If the display terminal or setup software is used, presence of the card is displayed in the IDENTIFICATION menu.

The following parameters are automatically configured by the card and cannot be modified:

- Assignment of logic inputs:
 - LI1 = Start/stop the installation
 - LI51 - LI52 - LI53 - LI54 - LI55
LO51 - LO52 - LO53 - LO54 - LO55

Parameter	Value
[Stop Key priority] (PSt)	[No] (nO)
[Profile] (CHCF)	[Separate] (SEP)
[Cmd switching] (CCS)	[ch1 active] (Cd1)
[Cmd channel 1] (Cd1)	[Prog. card] (APP)
[Cmd channel 2] (Cd2)	[Prog. card] (APP)
[Ref. 2 switching] (rFC)	[ch1 active] (Fr1)
[Ref.2 channel] (Fr2)	[No] (nO)
[Copy channel 1<->2] (COP)	[No] (nO)
[PID feedback ass.] (PIF)	[AI2] (AI2)
[Ramp switch ass.] (rPS)	[C411] (C411)

All the parameters are described in the Programming Manual.

[1.14 Multi pump] (SPL-) menu

The parameters in the **[1.14 Multi pump] (SPL-)** menu are coded "OXX", XX varying from 01 to 20: see the list of parameters on the following pages.

Operation using the graphic display terminal

Setting the date and time

In the [1.14 Multi pump] (SPL-) menu, [DATE/TIME SETTINGS] submenu, the following can be set:

- Year
- Month
- Day
- Hours
- Minutes

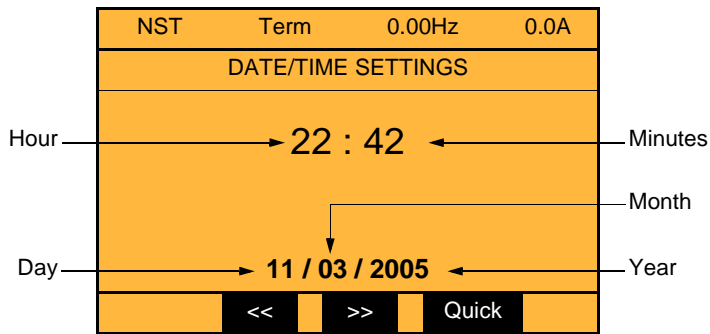

Note: The date and time are not refreshed on this settings screen. The current date and time [Date/Time] (CLO) can be displayed in the [1.2 MONITORING] (SUP-) menu.

Note: It is not possible to change either the date or time format:

- The date cannot be displayed in the "year/month/day" format.
- The time cannot be displayed in the "10:42 pm" format, only in the "22:42" format.

Note: It is not possible to configure changes between winter and summer time.

Menus - Parameter Setting

Parameters in the [1.14 Multi pump] (SPL-) menu

Code	Name	Function	Description	Unit	Range
O01	[Op. mode]	Selecting the operating mode	0: Pumps off 1: Single variable 2: Multiple variable 3: Single variable with changeover of auxiliary pumps 4: Multiple variable with changeover of auxiliary pumps 5: Single variable with limited relative operating time 6: Multiple variable with limited relative operating time 7: Single variable with changeover of auxiliary pumps and limited relative operating time 8: Multiple variable with changeover of auxiliary pumps and limited relative operating time		0 to 8
O02	[No. of pumps]	Total number of pumps connected	Includes the auxiliary pumps and the variable pump.		0 to 5
O03	[Pump Delay On]	Time delay before starting an auxiliary pump	This time is necessary to avoid the effects of transient pressure fluctuation and thus prevent oscillation (starting/stopping of the pump)	s	0 to 300
O04	[Pump Delay Off]	Time delay before the request to stop an auxiliary pump	This time is necessary to avoid the effects of transient pressure fluctuation and thus prevent oscillation (stopping/starting of the pump)	s	0 to 300
O05	[SleepFunctDel]	"Sleep" function time delay	If the frequency is below the "sleep" threshold after this time, the "sleep" function is activated.	s	0 to 3000
O06	[Acc Aux Pump]	Time delay for reaching the nominal speed of an auxiliary pump	Allows the auxiliary pump to reach its nominal speed before starting another pump (avoids oscillation)	s	0 to 300
O07	[Dec Aux Pump]	Time delay for stopping an auxiliary pump	Allows the auxiliary pump to reach its zero flow rate before stopping another pump (avoids oscillation)	s	0 to 300
O08	[Lim Rel Time]	Limited relative operating time	If the total operating time of a running auxiliary pump and a stopped pump differs by more than the time set in O08 , the first pump is stopped and replaced by the second. The unit can be changed from hours to minutes via the O17 parameter (see next page), in order to control operation.	h	0 to 3000
O09	[ResetOpTime]	Resets the operating counter of a pump	Select the pump number using this parameter. Press ENT. The operating time of the pump is reset and the parameter automatically returns to 0. Use when replacing a pump.		0 to 5
O10	[Pump no.]	Number of the pump with operating time displayed in O11	If O10 = 0, parameter o11 indicates the value of the pressure feedback.		0 to 5
O11	[Op. time]	Display of the operating time of the pump selected by O10	If O10 = 0, this parameter indicates the value of the pressure feedback (1).	h	0 to 65535

(1) The unit is determined by the [Min PID feedback] (PIF1) and [Max PID feedback] (PIF2) parameters, which are used to calibrate the PID feedback (sensor range). See example on page 14.

Menus - Parameter Setting

Code	Name	Function	Description	Unit	Range
O12	[FrqAuxPumpOn]	Starting frequency of a new auxiliary pump	Above this frequency and after the time delay for starting a pump (O03), another auxiliary pump starts.	Hz	O13 to [High Speed] (HSP)
O13	[FrqAuxPumpOff]	Stopping frequency of an auxiliary pump	Below this frequency and after the time delay for stopping an auxiliary pump (O04), the pump is stopped.	Hz	[Low speed] (LSP) to O12
O14	[Pr adj coeff]	Pressure adjustment coefficient	Coefficient used to adjust the pressure reference to compensate for loss of head when the hydraulic circuit is long.	(1)	0 to 32767
O15	[Sleep thresh]	"Sleep" threshold	This threshold activates the "sleep" time delay when the frequency is below that set by the parameter.	Hz	0 to [High speed] (HSP)
O16	[WUp thresh]	"Wake-up" threshold	Activates the variable pump and pressure regulation when the installation has been in "sleep" state.	(1)	0 to 9999
O17	[Time base]	Modification of the time base of O08	If O17 = 150, time O08 changes from hours to minutes, enabling quick checking of the changeover of the pumps during the debug or demonstration phase.		0 to 65535
O18	[V.pumpSwFr]	Frequency below which changeover of variable pumps is permitted	Determines the frequency below which changeover of the variable pump is possible if the relative operating time differential is reached. If O18 = 0.0Hz, the changeover can only be performed if the installation is in "sleep" state.	Hz	0 to [High speed] (HSP)

(1) The unit is determined by the [\[Min PID feedback\] \(PIF1\)](#) and [\[Max PID feedback\] \(PIF2\)](#) parameters, which are used to calibrate the PID feedback (sensor range). See example on page [14](#).

Architecture of the booster station

Single variable mode with 5 pumps: 1 variable speed pump and 4 fixed speed pumps (auxiliary pumps)

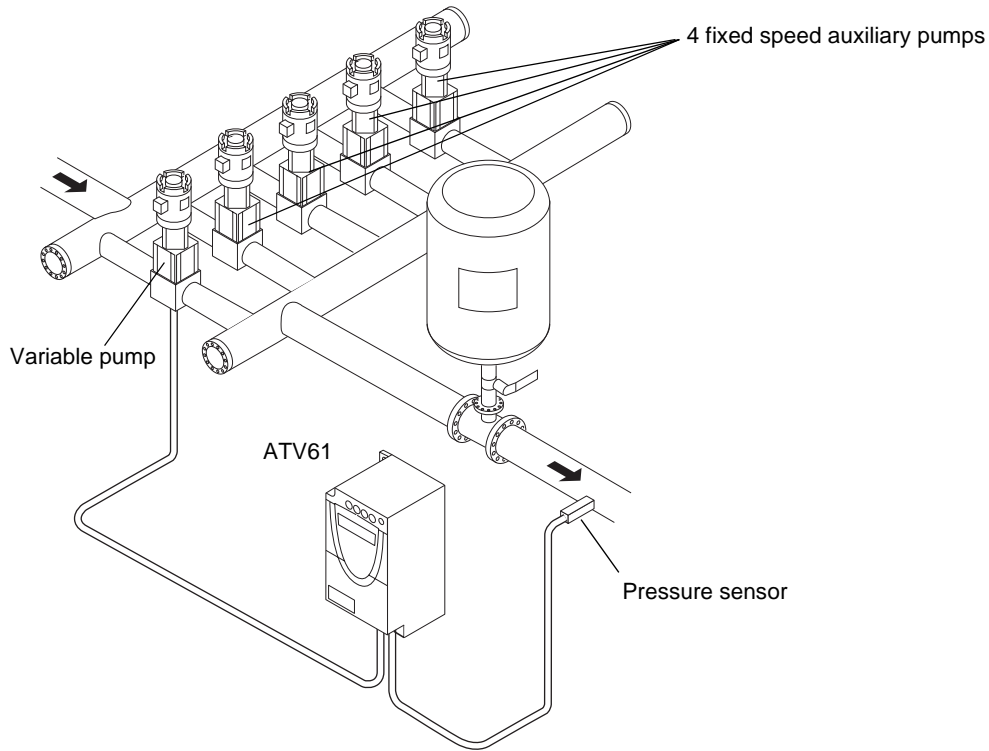

Connection diagrams

Example of single variable diagram with 5 pumps

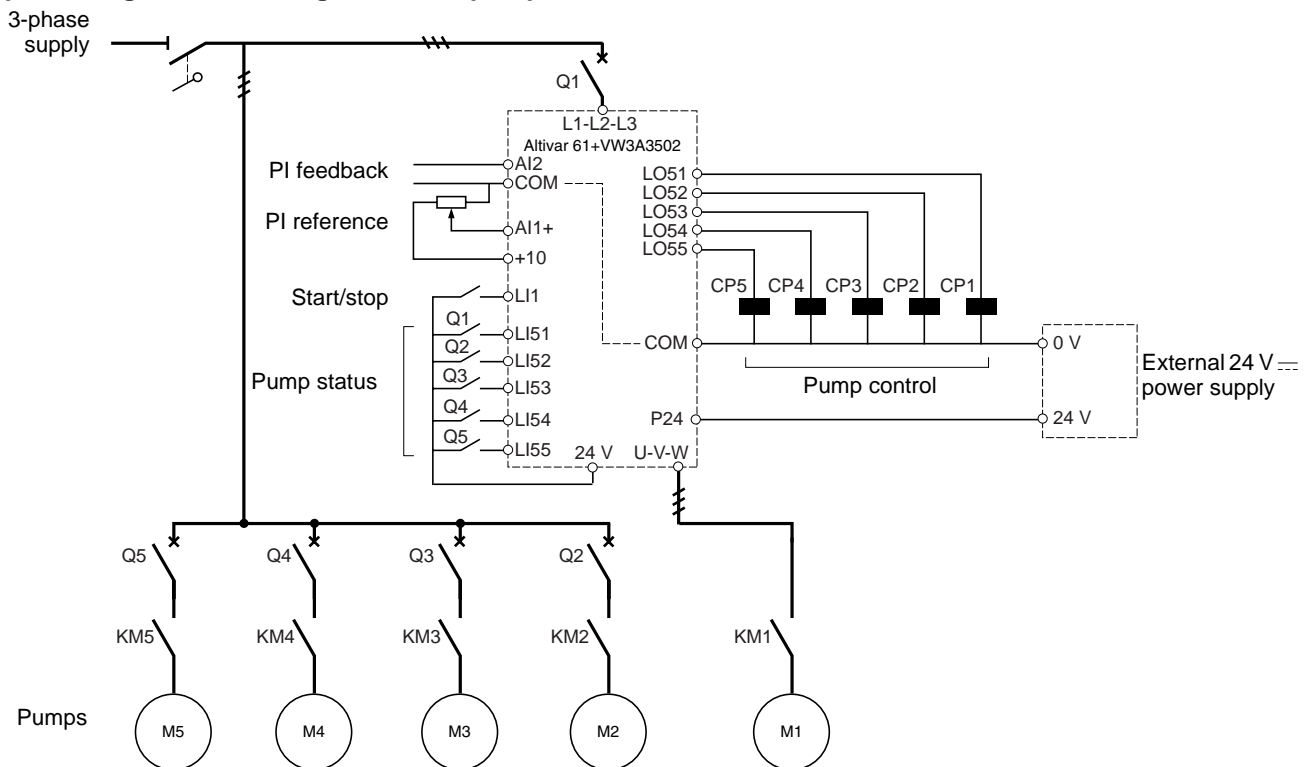

Each pump is controlled by a logic output.

- Pump 1 control via logic output LO51
- Pump 2 control via logic output LO52
- Pump 3 control via logic output LO53
- Pump 4 control via logic output LO54
- Pump 5 control via logic output LO55

The state of each pump must be sent back to the pump switching card via a logic input: 1 = the pump is ready to operate, 0 = the pump is faulty.

- State of pump 1 on logic input LI51
- State of pump 2 on logic input LI52
- State of pump 3 on logic input LI53
- State of pump 4 on logic input LI54
- State of pump 5 on logic input LI55

Example of single variable diagram with 5 pumps (continued)

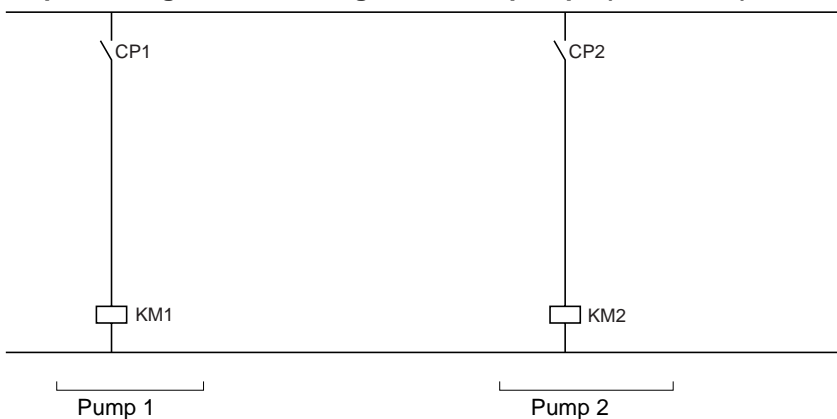

For pumps 3 to 5, same diagrams, incrementing the indices (KMx, CPx).

Connection diagrams

Example of multiple variable diagram with 5 pumps

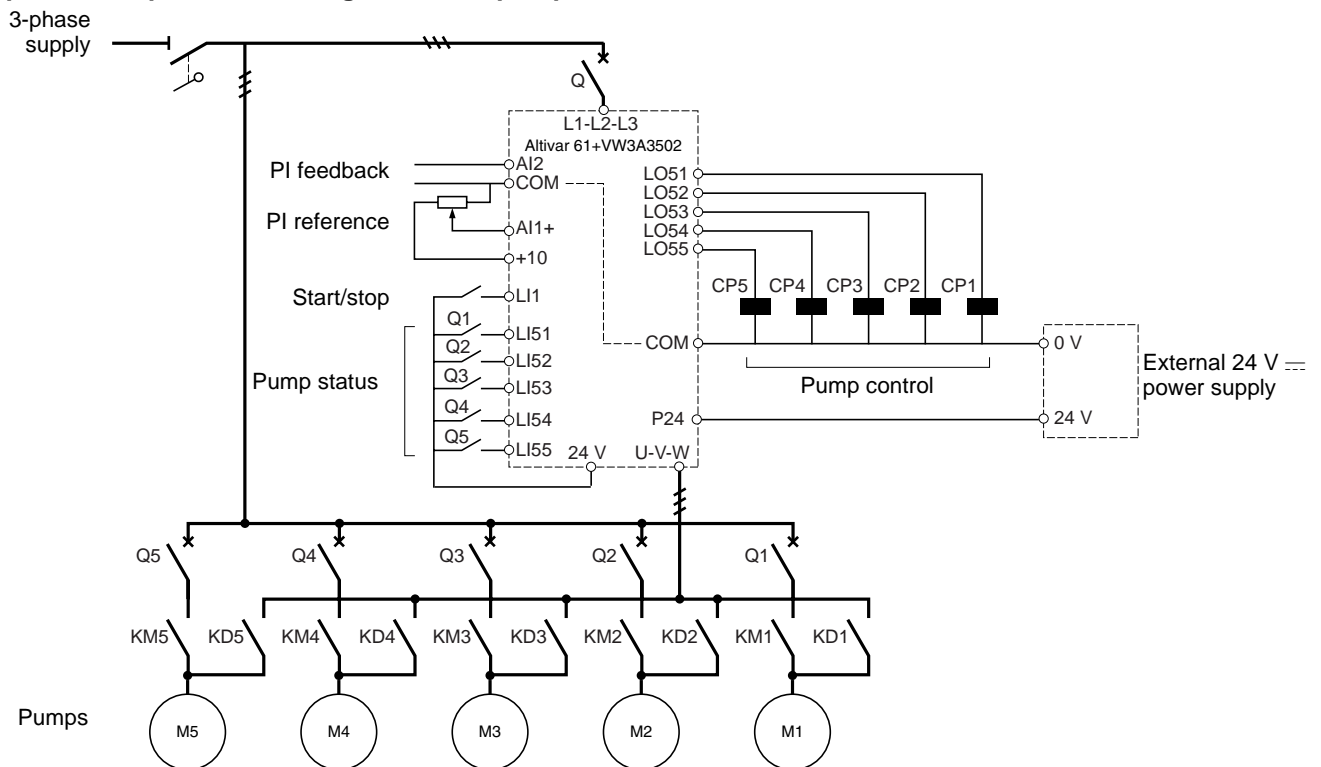

Each pump is controlled by a logic output.

- Pump 1 control via logic output LO51
- Pump 2 control via logic output LO52
- Pump 3 control via logic output LO53
- Pump 4 control via logic output LO54
- Pump 5 control via logic output LO55

The state of each pump must be sent back to the pump switching card via a logic input: 1 = the pump is ready to operate, 0 = the pump is faulty.

- State of pump 1 on logic input LI51
- State of pump 2 on logic input LI52
- State of pump 3 on logic input LI53
- State of pump 4 on logic input LI54
- State of pump 5 on logic input LI55

Example of multiple variable diagram with 5 pumps (continued)

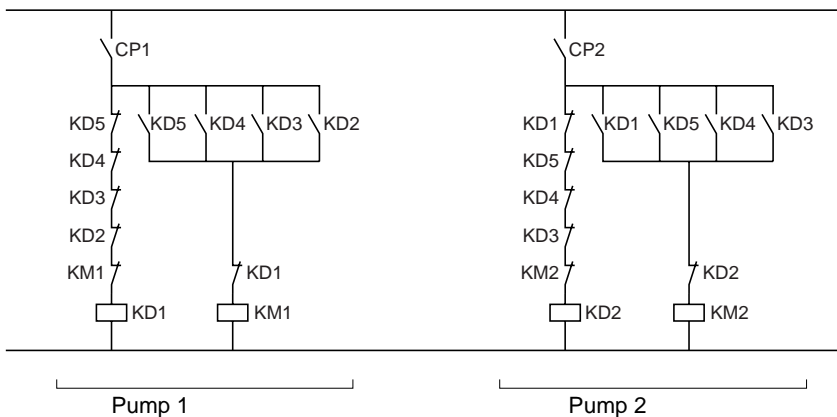

For pumps 3 to 5, same diagrams, incrementing the indices (KDx, KMx, CPx).

Connection diagrams

Example of multiple variable diagram with 5 pumps, with "manual/automatic" switching

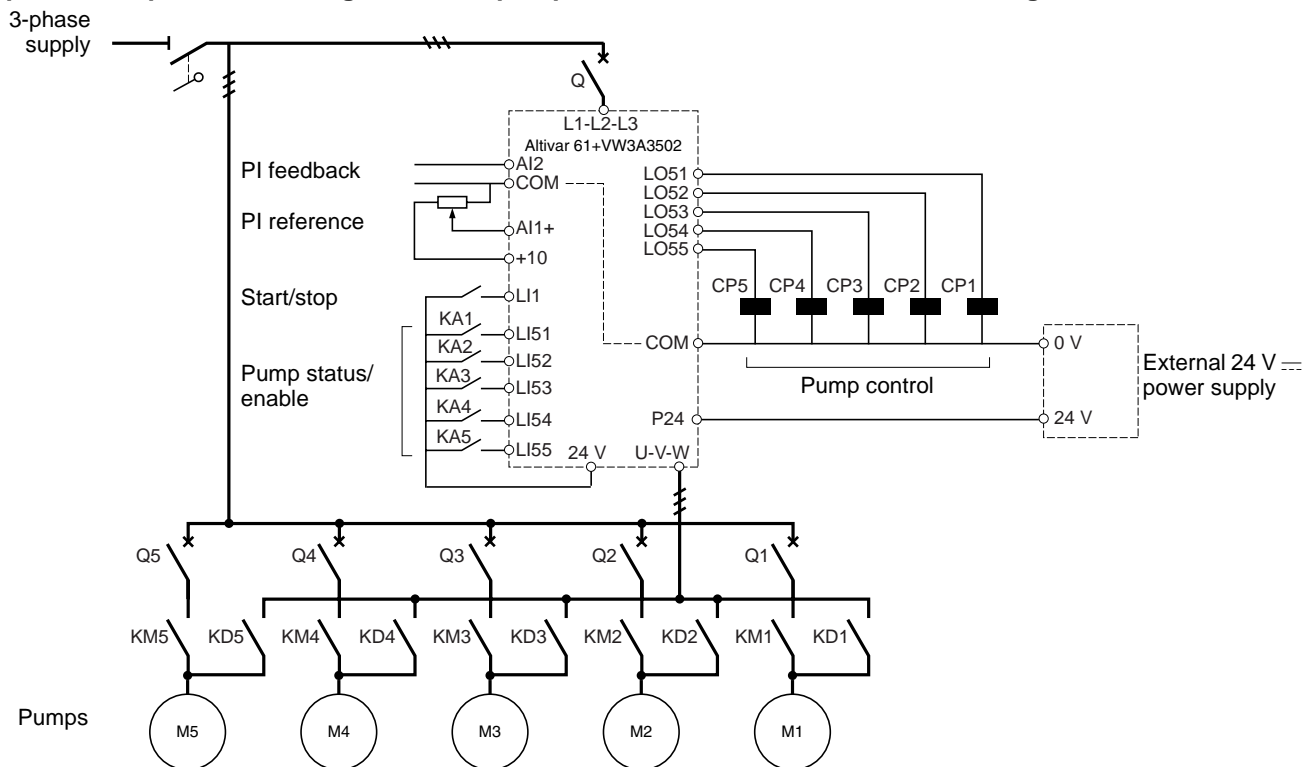

Each pump is controlled by a logic output.

- Pump 1 control via logic output LO51
- Pump 2 control via logic output LO52
- Pump 3 control via logic output LO53
- Pump 4 control via logic output LO54
- Pump 5 control via logic output LO55

The state and enabling of each pump must be sent back to the pump switching card via a logic input: 1 = the pump is enabled and ready to operate, 0 = the pump is faulty or disabled.

- State/enabling of pump 1 on logic input LI51
- State/enabling of pump 2 on logic input LI52
- State/enabling of pump 3 on logic input LI53
- State/enabling of pump 4 on logic input LI54
- State/enabling of pump 5 on logic input LI55

Example of multiple variable diagram with 5 pumps, with "manual/automatic" switching (continued)

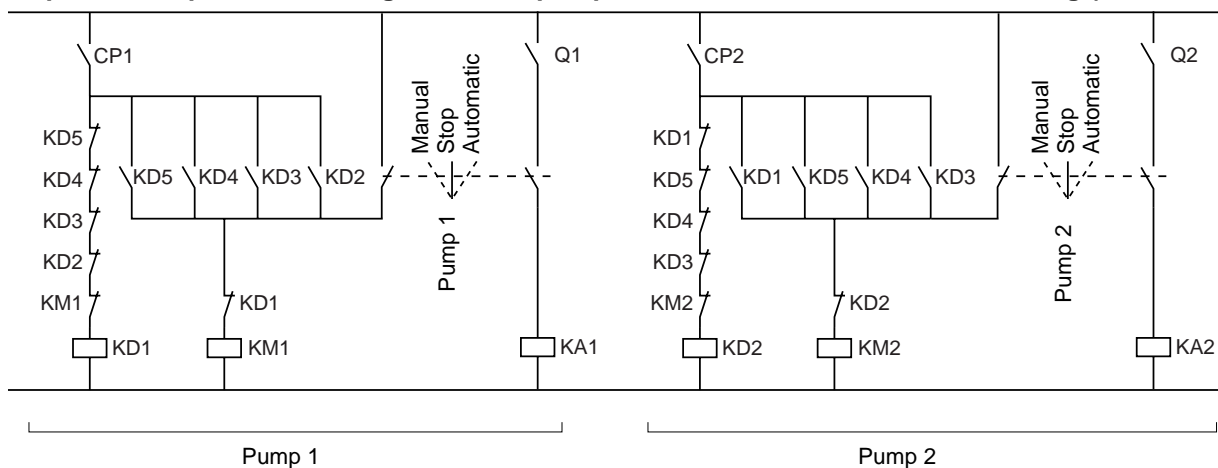

For pumps 3 to 5, same diagrams, incrementing the indices (Qx, KA_x, KD_x, KM_x, CP_x).

Setup

⚠ WARNING

RISK OF IMPROPER DRIVE OPERATION

The parameters in the **[1.14 Multi pump] (SPL-)** menu must be only modified when the drive is locked, i.e. when logic input LI1 is at 0. This procedure must also be carried out in the following cases:

- Transferring configuration files
- Saving a configuration file
- Writing a parameter via the RS485 serial link

Failure to follow these instructions can result in death, serious injury or equipment damage.

1 - Enter via the **[1.1 SIMPLY START] (SIM-)** menu

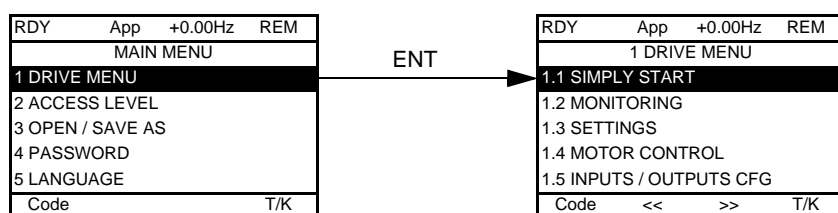

- Leave the pumping/ventilation macro configuration (factory setting).
- Enter data from the motor rating plate: **[Standard mot. freq.] (bFr)** - **[Rated motor power] (nPr)** - **[Rated motor volt.] (UnS)** - **[Rated mot. current] (nCr)** - **[Rated motor freq.] (FrS)** - **[Rated motor speed] (nSP)** parameters.
- Perform an auto tune operation: **[Auto tuning] (tUn)** parameter. In order to perform the auto tuning operation, the **[Op. mode] (O01)** parameter in the **[1.14 Multi pump] (SPL-)** menu must be 0, and a check must be carried out to ensure continuity of wiring between the drive and the motor (if there is an output contactor it must be closed).

2 - Configure the pressure feedback (must be input AI2)

AI2 is automatically assigned by the "pump switching card".

[1.5 INPUTS / OUTPUTS CFG] (I-O) menu

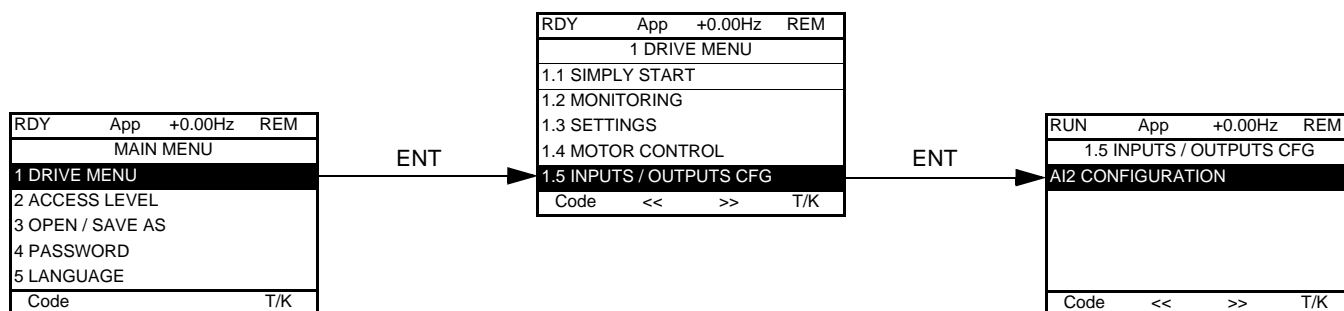

Configure AI2 according to the pressure sensor being used (Example: 4 - 20 mA)

3 - Configure the PID regulator reference

The "pump switching card" automatically assigns the PID reference to AI1. The factory configuration of AI1 is 0 - 10V.

The PID reference can be given by an internal reference:

- In the **[1.7 APPLICATION FUNCT.] (FUn-)** menu select the **[PID REGULATOR] (Pid-)** function and the **[Act. internal PID ref.] (PII) = [Yes] (YES)** parameter.
- The PID reference is then given by the **[Internal PID ref.] (rPI)** parameter.

Setup

4 - Check the wiring of the pumps

[1.2 MONITORING] (SUP-) menu

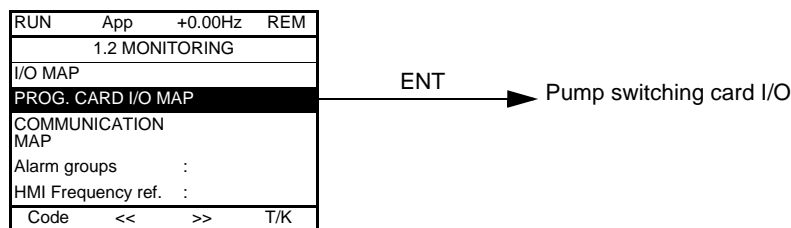

The presence of the pumps can be checked via the state of the logic inputs on the pump switching card.
LI51 LI52 LI53 LI54 LI55

Pump switching card I/O

RUN	App	+50.00Hz	REM
PROG. CARD I/O MAP			
PROG CARD LI MAP			
PROG. CARD AI MAP			
PROG CARD LO MAP			
PROG. CARD AO MAP			
Code	T/K		

Move from one screen to another
(from [PROG CARD LI MAP] to [PROG CARD AO MAP])
by turning the navigation button

- State 0
- State 1

RUN	App	+50.00Hz	REM
PROG CARD LI MAP			
1	LI51	LI52	LI53
0	LI54	LI55	LI56
	LI57	LI58	
1	LI59	LI60	
0			
<< >> T/K			

The "pump feedback" logic inputs are used to ascertain the state of the pumps.
In the above diagram Pumps No. 1, No. 2, and No. 3 are present.

5 - Check the direction of rotation of the variable pump

The direction of rotation of the variable pump can be checked by switching to "control via graphic display terminal" mode:

Press the T/K key (F4 = default T/K assignment).

Set a low speed reference and give a run command in order to check the direction of rotation of the variable pump.

All of the wiring must be checked in order to ensure that the direction of rotation of the auxiliary pumps is identical.

6 - Check the pressure sensor: stay in "control via graphic display terminal" mode

[1.2 MONITORING] (SUP-) menu

[I/O MAP]

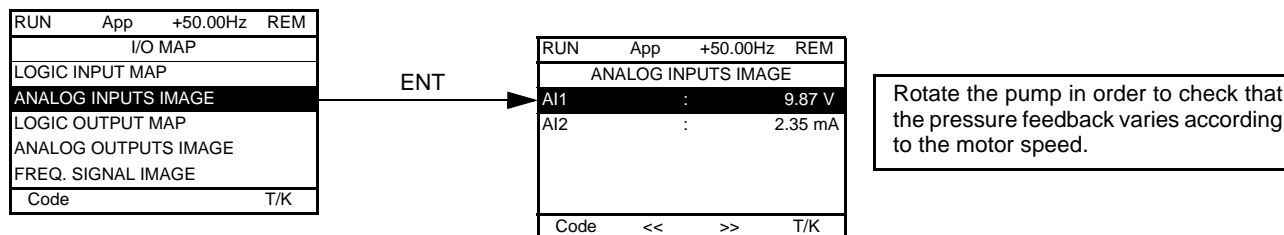

7 - Determine the cavitation threshold (See the characteristics of the pump)

If the cavitation threshold is not known, it can be determined in the following way:

- In "control via graphic display terminal" mode, set the speed reference to the nominal speed of the variable pump. The speed reference must then be gradually lowered (carry out tests at different initial flow rates). The flow rate decreases gradually then abruptly reaches the cavitation point (the speed of the pump no longer has any effect on the flow rate).
- In regulation mode, run the variable pump then gradually close the shutoff valve. The flow rate decreases, the pressure tends to increase, but the pressure regulation gradually reduces the speed of the pump to keep the pressure at the reference value. Read the frequency value when the flow rate approaches zero flow rate (before cavitation)

Adjust **[Low speed] (LSP)** to 1 or 2 Hz above the point at which the flow rate drops.
The default value can be around 30Hz for a standard centrifugal pump.

8 - Set the parameters of the "pump switching" application

Check first that the wiring diagram corresponds to the selected mode.

[1.14 Multi pump] (SPL-) menu

Set: the values in parentheses are given for information only: they depend on the characteristics of the pumps and the hydraulic system.

[Op. mode] (O01)	Selection of the operating mode
[No. of pumps] (O02)	Total number of pumps connected
[Pump Delay On] (O03)	Time delay before starting an auxiliary pump (3 to 5 s)
[Pump Delay Off] (O04)	Time delay before the request to stop an auxiliary pump (3 to 5 s)
[SleepFunctDel] (O05)	"Sleep" function time delay (30 s)
[Acc Aux Pump] (O06)	Time delay for reaching the nominal speed of an auxiliary pump (1 to 2 s)
[Dec Aux Pump] (O07)	Time delay for stopping an auxiliary pump (1 to 2 s)
[Lim Rel Time] (O08)	Limited relative operating time
[FrqAuxPumpOn] (O12)	Starting frequency of a new auxiliary pump: [High speed] (HSP) - 2Hz
[FrqAuxPumpOff] (O13)	Stopping frequency of an auxiliary pump: [High speed] (HSP) - 12 Hz
[Pr adj coeff] (O14)	Pressure adjustment coefficient
[Sleep thresh] (O15)	"Sleep" threshold: 3 to 4 Hz above [Low speed] (LSP)
[WUp thresh] (O16)	"Wake-up" threshold: a few % below the PID reference
[Time base] (O17)	Modifying the time base of [Lim Rel Time] (O08) , switches from a time base of hours to minutes, enabling quick checking of the changeover of the pumps during the debug or demonstration phase.
[V.pumpSwFr] (O18)	Frequency below which changeover of variable pumps is permitted.

Setup

9 - Set the PI regulator

[1.7 APPLICATION FUNCT.] (FUn-) menu, [PID REGULATOR] (Pid-)

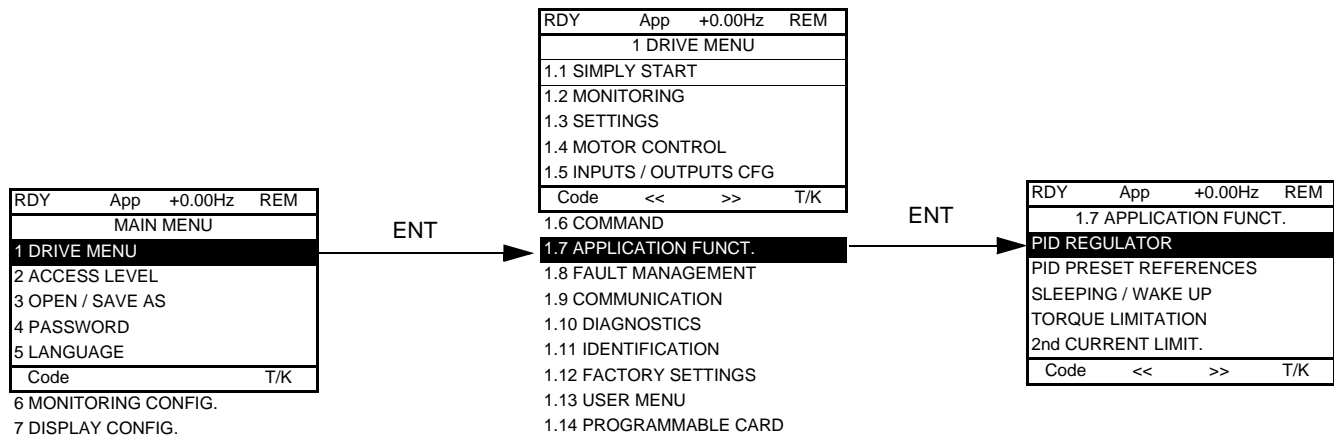

Example with a 0 - 10 bar sensor:

[Min PID feedback] (PIF1) = 0

[Max PID feedback] (PIF2) = 10,000 in order to have the best possible resolution

The maximum reference value for the process is 5 bar.

[Min PID reference] (PIP1) = 0

[Max PID reference] (PIP2) = 5,000

It can be adjusted from 0 to 5,000

Example for a 4 bar reference:

The reference is given by [Internal PID ref.] (rPI). To have a 4 bar reference, rPI must be set to 4000.

10 - Start the application

The PID regulator gains remain at their factory settings, and the application can be started. The PID starts smoothly with the [Acceleration 2] (AC2) ramp: 5 seconds default setting.

The process can now be debugged:

- If the process is not fast enough or if there is an error in steady state, increase the gain.
- Set the auxiliary pump activation and deactivation thresholds to avoid cascaded starts and stops when there are minor variations in demand.

Setup

11 - Customize the display

Create a graph display with the following parameters: **[PID reference] (rPC)** and **[PID feedback] (rPF)**

[6. MONITORING CONFIG.] menu

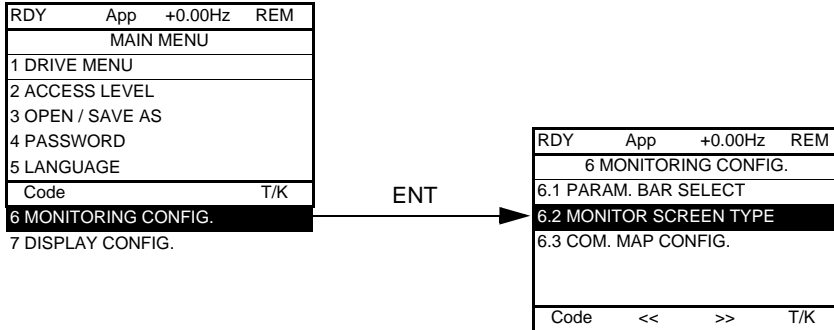

[6.2. MONITOR SCREEN TYPE]: Selection of parameters displayed in the centre of the screen and the display mode (digital values or bar graph format).

Deselect the current parameters and select **[PID reference] (rPC)** and **[PID feedback] (rPF)**

Select digital values display

RUN	App	+35.00Hz	REM
PID reference			
1250			
PID feedback			
1200			
Code			<< >> T/K

Setup

12 - Create a user menu with the parameters necessary for adjusting the application

Switch to Advanced mode. Go to the **[MAIN MENU]** and select **[2. ACCESS LEVEL] (LAC-)** = **[Advanced] (AdU)**.

RDY	App	+0.00Hz	REM
MAIN MENU			
1 DRIVE MENU			
2 ACCESS LEVEL			
3 OPEN / SAVE AS			
4 PASSWORD			
5 LANGUAGE			
Code	<<	>>	T/K

ENT →

RDY	App	+0.00Hz	REM
2 ACCESS LEVEL			
Basic			
Standard			
Advanced			
Expert			
Code	<<	>>	T/K

Go to the **[7 DISPLAY CONFIG.]** menu, then **[7.2 USER MENU]** to select the parameters required in the **[1.13 USER MENU] (Usr)**.

RDY	App	+0.00Hz	REM
MAIN MENU			
1 DRIVE MENU			
2 ACCESS LEVEL			
3 OPEN / SAVE AS			
4 PASSWORD			
5 LANGUAGE			
Code	<<	>>	T/K
6 MONITORING CONFIG.			
7 DISPLAY CONFIG.			

ENT →

RDY	App	+0.00Hz	REM
7 DISPLAY CONFIG.			
7.1 USER PARAMETERS			
7.2 USER MENU			
7.3 PARAMETER ACCESS			
Code	<<	>>	T/K

In the **[1.7 APPLICATION FUNCT.] (FUn-)** menu select → **[PID REGULATOR] (Pid-)** → **[PID prop. gain] (rPG)** and **[PID integral gain] (rIG)**

The following 2 parameters now appear in the **[1.13 USER MENU] (Usr-)**:

- **[PID prop. gain] (rPG)**
- **[PID integral gain] (rIG)**

RDY	App	+0.00Hz	REM
1.13 USER MENU			
PID integral gain : 1.00			
PID prop. gain : 1.00			
Code	<<	>>	T/K

Setup

13 - Create a display in customer units for the [PID reference] (rPC) and [PID feedback] (rPF) parameters

Example with a 0 - 10 bar sensor:

- [Min PID feedback] (PIF1) = 0
- [Max PID feedback] (PIF2) = 10,000 in order to have the best possible resolution in the operating range

Change the unit of the [PID reference] (rPC) and [PID feedback] (rPF) parameters and select mbar:

[MAIN MENU] → [7 DISPLAY CONFIG.] → [7.1 USER PARAMETERS] → select the parameters in [1.2 MONITORING] (SUP-): choose [PID reference] (rPC) and [PID feedback] (rPF).

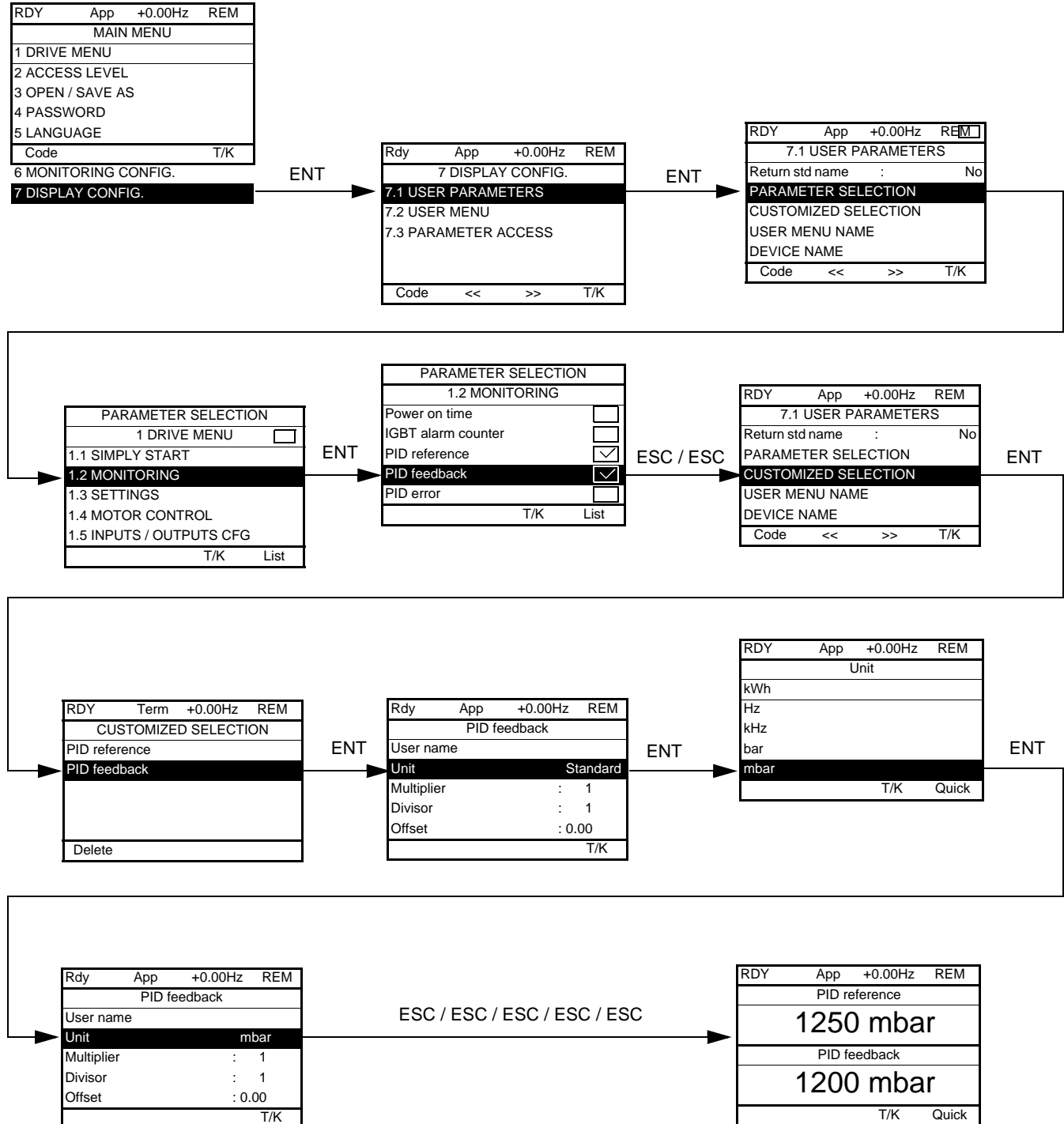

Setup

14 - Save the configuration

The configuration that has been created can be saved in the graphic display terminal.

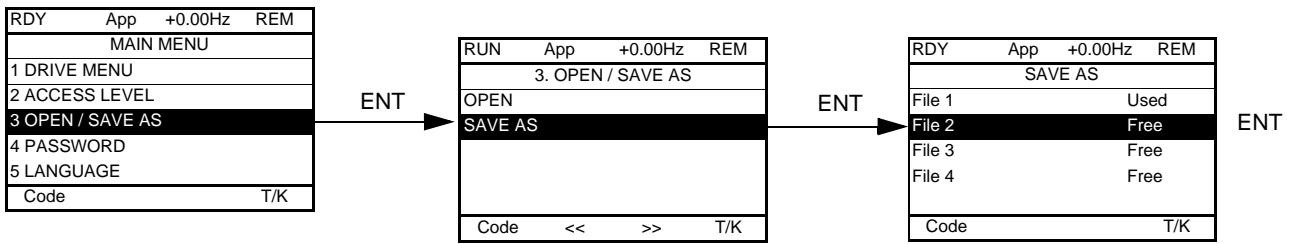

In the **[MAIN MENU]** screen, select **[SAVE AS]**:

To download the current drive configuration to the graphic display terminal.

