

---

When the drive is powered up, the power components and some of the control components are connected to the line supply. *It is extremely dangerous to touch them. The drive cover must be kept closed.*

In general, *the drive power supply must be disconnected* before any operation on either the electrical or mechanical parts of the installation or machine.

After the ALTIVAR has been switched off and the display has disappeared completely, *wait for 15 minutes before working on the equipment*. This is the time required for the capacitors to discharge.

The motor can be stopped during operation by inhibiting start commands or the speed reference while the drive remains powered up. If personnel safety requires prevention of sudden restarts, this electronic locking system is not sufficient: *fit a cut-off on the power circuit*.

The drive is fitted with safety devices which, in the event of a fault, can shut down the drive and consequently the motor. The motor itself may be stopped by a mechanical blockage. Finally, voltage variations, especially line supply failures, can also cause shutdowns.

If the cause of the shutdown disappears, there is a risk of restarting which may endanger certain machines or installations, especially those which must conform to safety regulations.

*In this case the user must take precautions against the possibility of restarts, in particular by using a low-speed detector to cut off power to the drive if the motor performs an unprogrammed shutdown.*

The drive must be installed and set up in accordance with both international and national standards. Bringing the device into conformity is the responsibility of the systems integrator who must observe the EMC directive among others within the European Union.

The specifications contained in this document must be applied in order to comply with the essential requirements of the EMC directive.

The Altivar 11 must be considered as a component: it is neither a machine nor a device ready for use in accordance with European directives (machinery directive and electromagnetic compatibility directive). It is the responsibility of the end user to ensure that the machine meets these standards.

The products and equipment described in this document may be changed or modified at any time, either from a technical point of view or in the way they are operated. Their description can in no way be considered contractual.

# Contents

---

Steps for Setting Up the Drive	66
Factory Configuration	67
Software Enhancements	68
Drive References	69
Mounting	72
Wiring	77
Basic functions	84
Setup - Preliminary recommendations	85
Programming	86
1st level adjustment parameters	89
Analog input menu Alt	90
Motor control menu drC	91
Application functions menu FUn	96
Display menu SUP	118
Maintenance	120
Faults - Causes - Remedies	121
Configuration/Settings Tables	123

# Steps for Setting Up the Drive

---

## 1 - Delivery of the drive

- Check that the drive reference printed on the label is the same as that on the delivery note corresponding to the purchase order.
- Remove the Altivar 11 from its packaging and check that it has not been damaged in transit.

## 2 - Fit the drive

### 3 - Connect the following to the drive:

- The line supply, ensuring that it is:
  - **within the voltage range of the drive**
  - **voltage free**
- The motor, ensuring that its connections correspond to the line voltage
- The control via the logic inputs
- The speed reference via the logic or analog inputs

## 4 - Switch on the drive, but do not give a run command

### 5 - Configure the following:

- The nominal frequency (bFr) of the motor, if it is other than 50 Hz for the E and A ranges or other than 60 Hz for the U range (only appears the first time the drive is switched on).
- The ACC (Acceleration) and dEC (Deceleration) parameters.
- The LSP (Low speed when the reference is minimum) and HSP (High speed when the reference is maximum) parameters.
- The lTh parameter (Motor thermal protection).
- The preset speeds SP2-SP3-SP4.

### 6 - Configure the following in the Alt menu:

- The speed reference if it is other than 0 - 5 V (0 - 10 V or 0 - 20 mA or 4 - 20 mA, or X - Y mA).

### 7 - Configure the following in the drC menu:

The motor parameters, only if the factory configuration of the drive is not suitable.

### 8 - Set the following in the FUn menu:

The application functions (only if the factory configuration of the drive is not suitable), for example the control mode: 3-wire, or 2-wire transitional, or 2-wire level detection, or 2-wire level detection with forward priority, or local control for the A and E327 ranges.

**The user must ensure that the programmed functions are compatible with the wiring diagram used.**

## 9 - Start the drive

## Factory settings

The Altivar 11 is factory-set for the most common operating conditions:

- Display: drive ready (rdY) motor stopped, and motor frequency reference in running
- Motor frequency (bFr): 50 Hz for the E and A ranges, 60 Hz for the U range
- Motor voltage (UnS): 230 V
- Ramps (ACC, dEC): 3 seconds
- Low speed (LSP): 0 Hz
- High speed (HSP): 50 Hz for the E and A ranges, 60 Hz for the U range
- Frequency loop gain: standard
- Motor thermal current (ItH) = nominal motor current (value depending on drive rating)
- Standstill injection braking current = 0.7 x nominal drive current, for 0.5 seconds
- Automatic adaptation of the deceleration ramp in the event of overvoltage on braking
- No automatic restarting after a fault
- Switching frequency 4 kHz
- Logic inputs:
  - LI1, LI2 (2 directions of operation): 2-wire transitional control, LI1 = forward, LI2 = reverse, inactive for the A and E327 ranges
  - LI3, LI4: 4 preset speeds (speed 1 = speed reference or LSP, speed 2 = 10 Hz, speed 3 = 25 Hz, speed 4 = 50 Hz)
- Analog input:
  - AI1 (0 + 5 V): 5 V speed reference, inactive for the A and E327 ranges
- Relay R1: the contact opens in the event of a fault (or drive off)
- Analog/logic output DO: as an analog output, image of the motor frequency

## A and E327 ranges

When they leave the factory, ATV 11●●●●●●A and ATV11●●●●●●E327 drives are supplied with local control activated: the RUN, STOP buttons and the drive potentiometer are active. Logic inputs LI1 and LI2 and analog input AI1 are inactive.

If the above values are compatible with the application, the drive can be used without changing the settings.

# Software Enhancements

---

Since it was first marketed, the Altivar ATV 11 has been equipped with additional functions. Software version V1.1 is now V1.2. This documentation relates to version V1.2.  
The software version appears on the rating plate attached to the side of the drive.

## New parameters in version V1.2 compared to V1.1

### Analog input menu **Alt**

- New menu, replacing and enhancing 1st level adjustment parameter **Alt** in version V1.1.

### Application functions menu **FUn**

- **tLS**: Operating time at low speed.
- **PI**: PI regulator (additional sub-menu)
- **LC2**: 2nd current limit
- **nSt**: Freewheel stop
- **SSr**: Speed reference configuration (on A and E327 ranges only).

### Display menu **SUP**

- **rPF**: PI sensor feedback
- **COd**: configuration protection by a code

# Drive References

## Single-phase supply voltage: 200...240 V 50/60 Hz

3-phase motor 200...240 V

Motor	Mains		Altivar 11			Reference (4)
Power indicated on plate (1)	Max. line current (2)	Max. prospective line Isc	Nominal current	Max. transient current (3)	Power dissipated at nominal load	
kW/HP	A	kA	A	A	W	

### E range (5)

0.18/0.25	2.9	1	1.1	1.6	12	ATV11HU05M2E
0.37/0.5	5.3	1	2.1	3.1	20.5	ATV11●U09M2E
0.55/0.75	6.3	1	3	4.5	29	ATV11●U12M2E
0.75/1	8.6	1	3.6	5.4	37	ATV11●U18M2E
1.5/2	14.8	1	6.8	10.2	72	ATV11HU29M2E
2.2/3	20.8	1	9.6	14.4	96	ATV11HU41M2E

### A range

0.18/0.25	3.3	1	1.4	2.1	14	ATV11HU05M2A
0.37/0.5	6	1	2.4	3.6	25	ATV11●U09M2A
0.75/1	9.9	1	4	6	40	ATV11●U18M2A
1.5/2	17.1	1	7.5	11.2	78	ATV11HU29M2A
2.2/3	24.1	1	10	15	97	ATV11HU41M2A

### U range

0.18/0.25	3.3	1	1.6	2.4	14.5	ATV11HU05M2U
0.37/0.5	6	1	2.4	3.6	23	ATV11●U09M2U
0.75/1	9.9	1	4.6	6.3	43	ATV11●U18M2U
1.5/2	17.1	1	7.5	11.2	77	ATV11HU29M2U
2.2/3	24.1	1	10.6	15	101	ATV11HU41M2U

(1) These power ratings are for a switching frequency of 4 kHz, in continuous operation. The switching frequency is adjustable from 2 to 16 kHz.

Above 4 kHz, the drive will reduce the switching frequency if an excessive temperature rise occurs. The temperature rise is controlled by a PTC probe in the power module. Nonetheless, derating should be applied to the nominal drive current if operation above 4 kHz needs to be continuous:

- 10% derating for 8 kHz
- 20% derating for 12 kHz
- 30% derating for 16 kHz

(2) Nominal voltage values: 230 V for the E range, 200 V for the A range and 208 V for the U range.

(3) For 60 seconds.

(4) Drives whose reference contains a ● are available in two versions:

- on heatsink, replace the ● with an H (ATV11HU09M2E for example)
- on base plate, replace the ● with a P (ATV11PU09M2E for example)

(5) These drives are available with RUN and STOP buttons and the potentiometer (like the A range). In this case, the reference has 327 added at the end. Eg: ATV11HU05M2E327

# Drive References

## 3-phase supply voltage: 200...230 V 50/60 Hz

3-phase motor 200...230 V

Motor	Mains		Altivar 11			
Power indicated on plate (1)	Max. line current (2)	Max. prospective line Isc	Nominal current	Max. transient current (3)	Power dissipated at nominal load	Reference (4)
kW/HP	A	kA	A	A	W	

### A range

0.18/0.25	1.8	5	1.4	2.1	13.5	<b>ATV11HU05M3A</b>
0.37/0.5	3.6	5	2.4	3.6	24	<b>ATV11●U09M3A</b>
0.75/1	6.3	5	4	6	38	<b>ATV11●U18M3A</b>
1.5/2	11	5	7.5	11.2	75	<b>ATV11HU29M3A</b>
2.2/3	15.2	5	10	15	94	<b>ATV11HU41M3A</b>

### U range

0.18/0.25	1.8	5	1.6	2.4	13.5	<b>ATV11HU05M3U</b>
0.37/0.5	3.6	5	2.4	3.6	24	<b>ATV11●U09M3U</b>
0.75/1	6.3	5	4.6	6.3	38	<b>ATV11●U18M3U</b>
1.5/2	11	5	7.5	11.2	75	<b>ATV11HU29M3U</b>
2.2/3	15.2	5	10.6	15	94	<b>ATV11HU41M3U</b>

(1) These power ratings are for a switching frequency of 4 kHz, in continuous operation. The switching frequency is adjustable from 2 to 16 kHz.

Above 4 kHz, the drive will reduce the switching frequency if an excessive temperature rise occurs. The temperature rise is controlled by a PTC probe in the power module. Nonetheless, derating should be applied to the nominal drive current if operation above 4 kHz needs to be continuous:

- 10% derating for 8 kHz, 20% for 12 kHz, 30% for 16 kHz

(2) Nominal voltage values: 200 V for the A range and 208 V for the U range.

(3) For 60 seconds.

(4) Drives whose reference contains a ● are available in two versions:

- on heatsink, replace the ● with an H (ATV11HU09M3A for example)
- on base plate, replace the ● with a P (ATV11PU09M3A for example)

# Drive References

## Single phase supply voltage: 100...120 V 50/60 Hz

3-phase motor 200...230 V

Motor	Mains	Altivar 11				Reference (4)
Power indicated on plate (1)	Max. line current (2)	Max. prospective line Isc	Nominal current	Max. transient current (3)	Power dissipated at nominal load	
kW/HP	A	kA	A	A	W	

### A range

0.18/0.25	6	1	1.4	2.1	14	<b>ATV11HU05F1A</b>
0.37/0.5	9	1	2.4	3.6	25	<b>ATV11●U09F1A</b>
0.75/1	18	1	4	6	40	<b>ATV11HU18F1A</b>

### U range

0.18/0.25	6	1	1.6	2.4	14.5	<b>ATV11HU05F1U</b>
0.37/0.5	9	1	2.4	3.6	23	<b>ATV11●U09F1U</b>
0.75/1	18	1	4.6	6.3	43	<b>ATV11HU18F1U</b>

(1) These power ratings are for a switching frequency of 4 kHz, in continuous operation. The switching frequency is adjustable from 2 to 16 kHz.

Above 4 kHz, the drive will reduce the switching frequency if an excessive temperature rise occurs. The temperature rise is controlled by a PTC probe in the power module. Nonetheless, derating should be applied to the nominal drive current if operation above 4 kHz needs to be continuous:

- 10% derating for 8 kHz, 20% for 12 kHz, 30% for 16 kHz

(2) Values for 100 V nominal voltage.

(3) For 60 seconds.

(4) Drives whose reference contains a ● are available in two versions:

- on heatsink, replace the ● with an H (ATV11HU09F1A for example)
- on base plate, replace the ● with a P (ATV11PU09F1A for example)

# Mounting

## Dimensions and weights

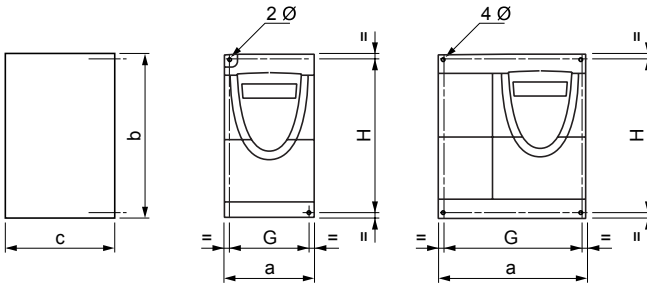

ATV 11H	a mm	b mm	c (1) mm	G mm	H mm	Ø mm	Screws	Weight kg
U05●● E, A, U ranges	72	142	101	60±1	131±1	2 x 5	M4	0.70
U09●● E range	72	142	125	60±1	120±1	2 x 5	M4	0.85
U09●● A, U ranges	72	142	125	60±1	131±1	2 x 5	M4	0.85
U12●● E range	72	142	138	60±1	120±1	2 x 5	M4	0.92
U18M● E range								
U18M● A range	72	142	138	60±1	131±1	2 x 5	M4	0.92
U18M● U range	72	147	138	60±1	131±1	2 x 5	M4	0.95
U18F1 A, U ranges	117	142	156	106±0.5	131±1	4 x 5	M4	1.6
U29●● E, A, U ranges								
U41●● E, A, U ranges								

ATV 11P	a mm	b mm	c (1) mm	G mm	H mm	Ø mm	Screws	Weight kg
All ratings	72	142	101	60±1	131±1	2 x 5	M4	0.67

(1) For drives in the A and E327 ranges, add 7 mm for the protruding potentiometer button.

## Mounting and temperature conditions

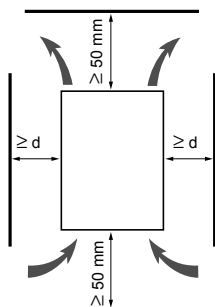

Install the unit vertically, at  $\pm 10^\circ$ .

Do not place it close to heating elements.

Leave sufficient free space to ensure that the air required for cooling purposes can circulate from the bottom to the top of the unit.

Free space in front of unit: 10 mm minimum.

When IP20 protection is adequate, we recommend that the protective cover on the top of the drive be removed, as shown below.

- From  $-10^\circ\text{C}$  to  $40^\circ\text{C}$ :
  - $d \geq 50$  mm: no special precautions.
  - $d = 0$  (mounted side by side): remove the protective cover on the top of the drive, as shown below (the degree of protection becomes IP20).
- From  $40^\circ\text{C}$  to  $50^\circ\text{C}$ :
  - $d \geq 50$  mm: remove the protective cover on the top of the drive, as shown below (the degree of protection becomes IP20).  
If the cover is left on, derate the nominal drive current by 2.2% for every  $^\circ\text{C}$  above  $40^\circ\text{C}$ .
  - $d = 0$ : remove the protective cover on the top of the drive, as shown below (the degree of protection becomes IP20), and derate the nominal drive current by 2.2% for every  $^\circ\text{C}$  above  $40^\circ\text{C}$ .
- From  $50^\circ\text{C}$  to  $60^\circ\text{C}$ :
  - $d \geq 50$  mm: remove the protective cover on the top of the drive, as shown below (the degree of protection becomes IP20), and derate the nominal drive current by 2.2% for every  $^\circ\text{C}$  above  $50^\circ\text{C}$ .

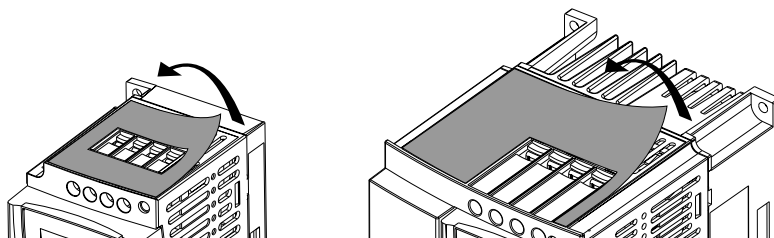

## Mounting the drives on base plates

ATV 11P●●●●● drives can be mounted on (or in) a steel or aluminium machine frame, observing the following conditions:

- Maximum ambient temperature: 40 °C
- Vertical mounting at  $\pm 10^\circ$
- The drive must be fixed at the centre of a support (frame) which is a minimum of 10 mm thick and with a minimum square cooling area (S) of 0.12 m<sup>2</sup> for steel and 0.09 m<sup>2</sup> for aluminium, exposed to the open air.
- Support area for the drive (min 142 x 72) machined on the frame with a surface smoothness of 100  $\mu\text{m}$  max and unevenness of 3.2  $\mu\text{m}$  max.
- Deburr the tapped holes.
- Coat the whole support surface of the drive with thermal contact grease (or equivalent).

Attach the drive using  
2 x M4 screws (not  
supplied).

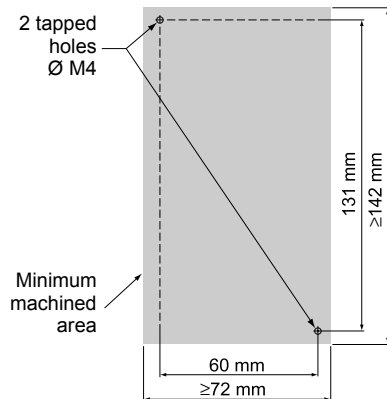
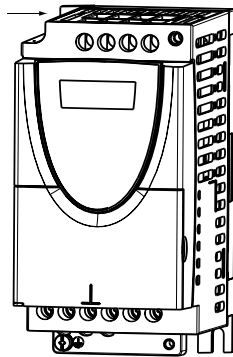
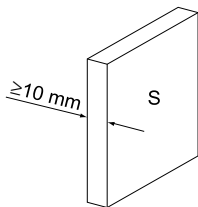

Verify the thermal state of the drive by checking parameter tHd (SUP menu), to confirm that the drive has been mounted correctly.

# Mounting

## Electromagnetic compatibility

### EMC mounting plate: VW3 A11821 to be ordered separately

Fix the EMC equipotentiality mounting plate to the holes in the ATV 11 heatsink using the 2 screws supplied, as shown in the drawings below.

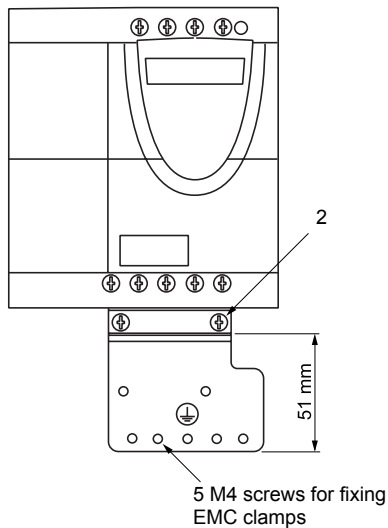
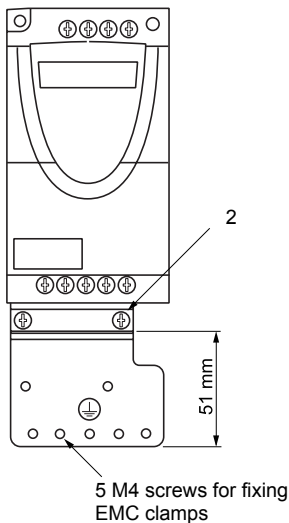



## Power terminals

The power terminals can be accessed without opening the cover. The drive has through wiring: line supply is at the top of the drive (R/L1-S/L2 in single-phase 230V, R/L1-S/L2-T/L3 in 3-phase 230V, R/L1-N in single-phase 120V), the motor power supply is at the bottom of the drive (U - V - W).



**Connect the power terminals before connecting the control terminals.**

## Specifications of power terminals

Altivar ATV 11●	Maximum connection capacity		Tightening torque in Nm
	AWG	mm <sup>2</sup>	
U05●●●, U09●●●, U18M●●	AWG 14	1.5	0.75
U18F1●, U29●●●, U41●●●	AWG 10	4	1

## Functions of power terminals

Terminals	Function	For Altivar ATV 11
⏏	Earth terminal	All ratings
R/L1 - S/L2/N	Power supply	ATV11●●●●M2●
R/L1 - S/L2 - T/L3		ATV11●●●●M3●
R/L1 - N		ATV11●●●●F1●
PA/+	+ output (---) to the braking module	All ratings
PC/-	- output (---) to the braking module	All ratings
U - V - W	Outputs to the motor	All ratings
⏏	Earth terminal	All ratings

## Arrangement of the power terminals

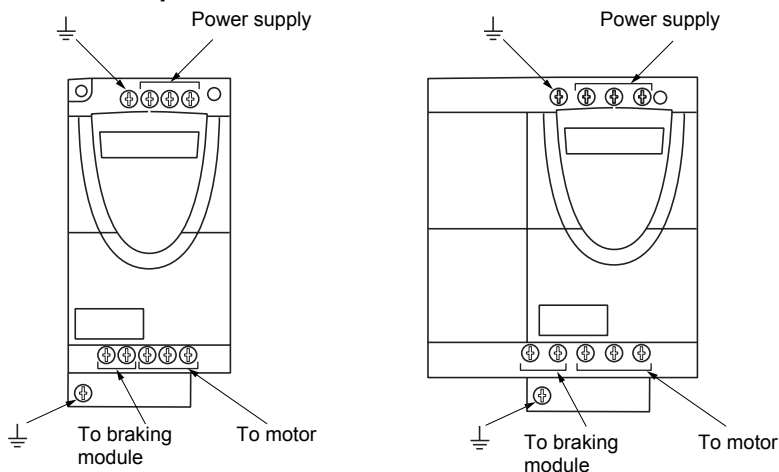

## Control terminals

To access the control terminals, open the cover as shown below.

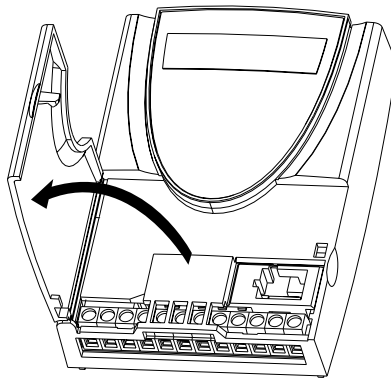

ENGLISH

### Arrangement, specifications and functions of the control terminals

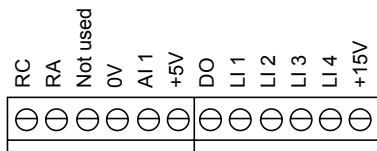

- Maximum connection capacity:  
1.5 mm<sup>2</sup> - AWG 14
- Max. tightening torque:  
0.5 Nm.

Terminal	Function	Electrical characteristics
RC RA	Fault relay contact (open if there is a fault or the drive is disconnected)	Min. switching capacity: • 10 mA for 24 V $\overline{\text{DC}}$ Max. switching capacity: • 2 A for 250 V $\sim$ and 30 V $\overline{\text{DC}}$ on inductive load ( $\cos \varphi = 0.4$ and $L/R = 7$ ms) • 5 A for 250 V $\sim$ and 30 V $\overline{\text{DC}}$ on resistive load ( $\cos \varphi = 1$ and $L/R = 0$ ) • sampling time 20 ms max.

## Arrangement, specifications and functions of the control terminals (continued)

Terminal	Function	Electrical characteristics
0V	I/O common	0 V
AI1	Voltage or current analog input	<p>Analog input 0 + 5 V or 0 + 10 V (max. voltage 30 V)</p> <ul style="list-style-type: none"> <li>• impedance 40 k<math>\Omega</math></li> <li>• resolution 0.4%</li> <li>• precision, linearity: <math>\pm 5\%</math></li> <li>• sampling time 20 ms max.</li> </ul> <p>Analog input 0 - 20 mA or 4 - 20 mA</p> <ul style="list-style-type: none"> <li>• impedance 250 <math>\Omega</math> (with no additional resistor)</li> <li>• resolution 0.4%</li> <li>• precision, linearity: <math>\pm 5\%</math></li> <li>• sampling time 20 ms max.</li> </ul>
+5V	Power supply for reference potentiometer 2.2 to 10 k $\Omega$	<ul style="list-style-type: none"> <li>• precision: <math>\pm 5\%</math></li> </ul>
DO	Output which can be configured as analog or logic output	<p>PWM open collector analog output at 2 kHz:</p> <ul style="list-style-type: none"> <li>• voltage 30 V max.</li> <li>• impedance 1 k<math>\Omega</math>, 10 mA max.</li> <li>• linearity <math>\pm 1\%</math></li> <li>• sampling time 20 ms max.</li> </ul> <p>Open collector logic output:</p> <ul style="list-style-type: none"> <li>• voltage 30 V max.</li> <li>• impedance 100 <math>\Omega</math>, 50 mA max.</li> <li>• sampling time 20 ms max.</li> </ul>
LI1 LI2 LI3 LI4	Logic inputs	<p>Programmable logic inputs</p> <ul style="list-style-type: none"> <li>• +15 V power supply (max. 30 V)</li> <li>• impedance 5 k<math>\Omega</math></li> <li>• state 0 if &lt; 5 V, state 1 if &gt; 11 V in positive logic</li> <li>• state 1 if &lt; 5 V, state 0 if &gt; 11 V or switched off (not connected) in negative logic</li> <li>• sampling time 20 ms max.</li> </ul>
+15V	Logic input power supply	<p>+ 15 V <math>\pm 15\%</math> protected against short-circuits and overloads. Max. customer current available 100 mA</p>

## Wiring diagram for factory settings

Single-phase supply 100...120 V

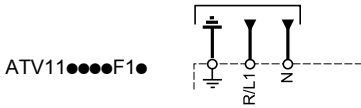

Single-phase supply 200...230 V

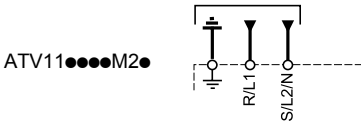

3-phase supply 200...240 V

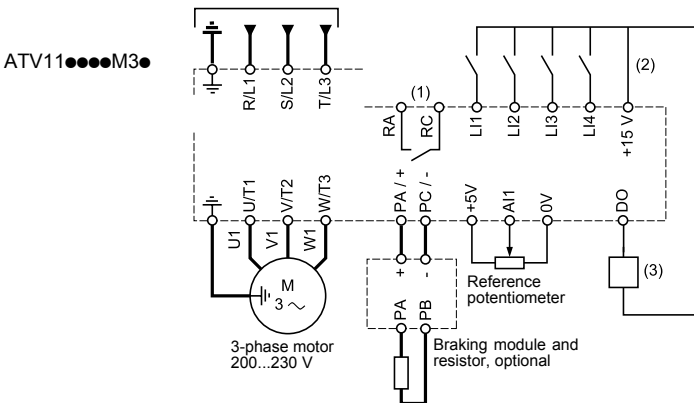

(1) Fault relay contacts, for remote indication of the drive status.

(2) Internal + 15 V. If an external source is used (+ 24 V max.), connect the 0 V of the source to the 0 V terminal, and do not use the + 15 V terminal on the drive.

(3) Galvanometer or low level relay.

**Note:** Fit interference suppressors to all inductive circuits near the drive or coupled to the same circuit (relays, contactors, solenoid valves, etc).

### Choice of associated components:

See the Altivar 11 catalog.

### Use of a braking resistor:

It is essential to add a VW3 A11701 braking module between the drive and the resistor.

## Replacing an ATV08 with an ATV11



**Caution, when replacing an ATV08 with an ATV11:**  
The control terminals are arranged and marked differently:

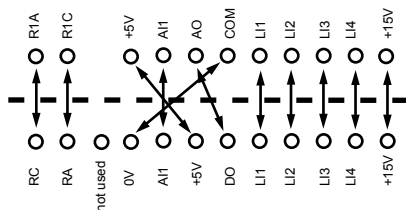

## Wiring recommendations

### Power

Observe the cable cross-sectional areas recommended in the standards.

The drive must be earthed to conform with the regulations concerning high leakage currents (over 3.5 mA). When upstream protection by means of a "residual current device" is required by the installation standards, a type A device should be used for single-phase drives and type B for 3-phase drives. Choose a suitable model incorporating:

- HF current filtering
- a time delay which prevents tripping caused by the load from stray capacitance on power-up. The time delay is not possible for 30 mA devices. In this case, choose devices with immunity against accidental tripping, for example RCDs with reinforced immunity from the **s.i** range (Merlin Gerin brand).

If the installation includes several drives, provide one "residual current device" per drive.

Keep the power cables separate from circuits in the installation with low-level signals (detectors, PLCs, measuring apparatus, video, telephone).

### Control

Keep the control circuits away from the power cables. For control and speed reference circuits, we recommend using shielded twisted cables with a pitch of between 25 and 50 mm, connecting the shielding to ground at each end.



- 1 Sheet steel grounded casing not supplied with the drive (VW3A11831), to be fitted as indicated on the diagram.
- 2 Altivar 11
- 3 Non-shielded power supply wires or cable
- 4 Non-shielded wires for the output of the fault relay contacts.
- 5 Fix and ground the shielding of cables 6 and 7 as close as possible to the drive:
  - strip the shielding
  - use cable clamps of an appropriate size on the parts from which the shielding has been stripped, to attach them to the casing 1.The shielding must be clamped tightly enough to the metal plate to ensure correct contact.
  - types of clamp: stainless steel
- 6 Shielded cable for motor connection with shielding connected to ground at both ends.

This shielding must be continuous, and if there are any intermediate terminals, these must be in an EMC shielded metal box. The motor cable PE protective conductor (green-yellow) must be connected to the grounded casing, for example under the metal clamp.
- 7 Shielded cable for connecting the control/signalling wiring.

For applications requiring several conductors, use small cross-sections (0.5 mm<sup>2</sup>).

The shielding must be connected to ground at both ends. The shielding must be continuous and intermediate terminals must be in EMC shielded metal boxes.
- 8 Protective conductor, cross-section 10 mm<sup>2</sup>.

**Note:**

- If using an additional input filter, it should be mounted under the drive and connected directly to the line supply via an unshielded cable. Link 3 on the drive is via the filter output cable.
- The HF equipotential ground connection between the drive, motor and cable shielding does not remove the need to connect the PE protective conductors (green-yellow) to the appropriate terminals on each unit.

## Fault relay, unlocking

The fault relay is closed when the drive is switched on and is not faulty. It opens in the event of a fault or when the drive is disconnected.

The drive is unlocked after a fault:

- by switching off the drive until the display disappears completely, then switching on again
- automatically in the cases described in the "automatic restart" function (FUn menu, Atr = YES)
- via a logic input when this input is assigned to the "fault reset" function (FUn menu, rSF = Li●)

## Drive thermal protection

Thermal protection via a built-in PTC probe in the power module.

## Drive ventilation

Certain drive ratings include forced ventilation: ATV 11HU18F1A, ATV 11HU18F1U, ATV 11●U18M2U, ATV 11●U18M3U, ATV 11HU29●●●, ATV 11HU41●●●

The fan is supplied with power automatically as soon as the drive is switched on.

## Motor thermal protection

### Function:

Thermal protection by calculating the  $I^2t$ .



**The memory of the motor thermal state returns to zero when the drive is disconnected.**

# Setup - Preliminary recommendations

---

## Prior to switching on and configuring the drive



- Ensure the logic inputs are open circuit (state 0) to prevent an accidental startup. Otherwise, an input assigned to the run command may cause the motor to start immediately on exiting the configuration menus.

## With power switching via line contactor



- Avoid operating the contactor frequently (premature ageing of the filter capacitors). Use inputs LI1 to LI4 to control the drive.  
- These instructions are vital for cycles < 5 minutes, otherwise the load resistor may be damaged.

## User adjustment and extension of functions

If necessary, the display and buttons can be used to modify the settings and to extend the functions described in the following pages. It is very easy to return to the factory settings.



Check that changes to the current operating settings do not present any danger. Changes should preferably be made with the drive stopped.

## Functions of the display and the keys E and U ranges:

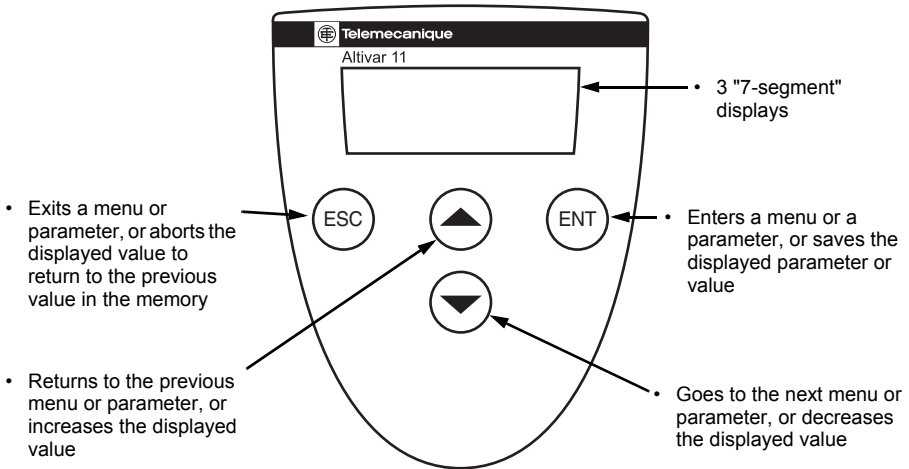

ENGLISH



Pressing ▲ or ▼ does not store the selection.

**Save and store the selection:** ENT

The display flashes when a value is stored.

**Normal display, with no fault present and no startup:**

- rdY: Drive ready
- 43.0: Display of the parameter selected in the SUP menu (default selection: frequency reference).
- dcb: DC injection braking in progress
- nSt: Freewheel stop

**If there is a fault, it is shown with a flashing display.**

## Functions of the display and the keys A and E327 ranges:

- Returns to the previous menu or parameter, or increases the displayed value
- Exits a menu or parameter, or aborts the displayed value to return to the previous value in the memory

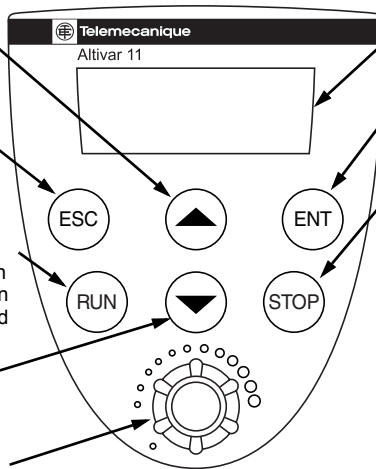

- RUN button: controls the switching on of the motor in the forward, if parameter tCC in the FUN menu is configured as LOC
- Goes to the next menu or parameter, or decreases the displayed value
- Reference potentiometer, active if parameter LSr in the FUN menu is configured as LOC

- 3 "7-segment" displays
- Enters a menu or a parameter, or saves the displayed parameter or value
- STOP button: always controls the stopping of the motor.
  - If tCC (FUN menu) is not configured as LOC, it is a freewheel stop.
  - If tCC (FUN menu) is configured as LOC, the stop is on a ramp, but if injection braking is in progress, a freewheel stop takes place.



Pressing ▲ or ▼ does not store the selection.

Save and store the selection: ENT

The display flashes when a value is stored.

### Normal display, with no fault present and no startup:

- rdY: Drive ready
- 43.0: Display of the parameter selected in the SUP menu (default selection: frequency reference).
- dcb: DC injection braking in progress
- nSt: Freewheel stop

If there is a fault, it is shown with a flashing display.

## Access to menus

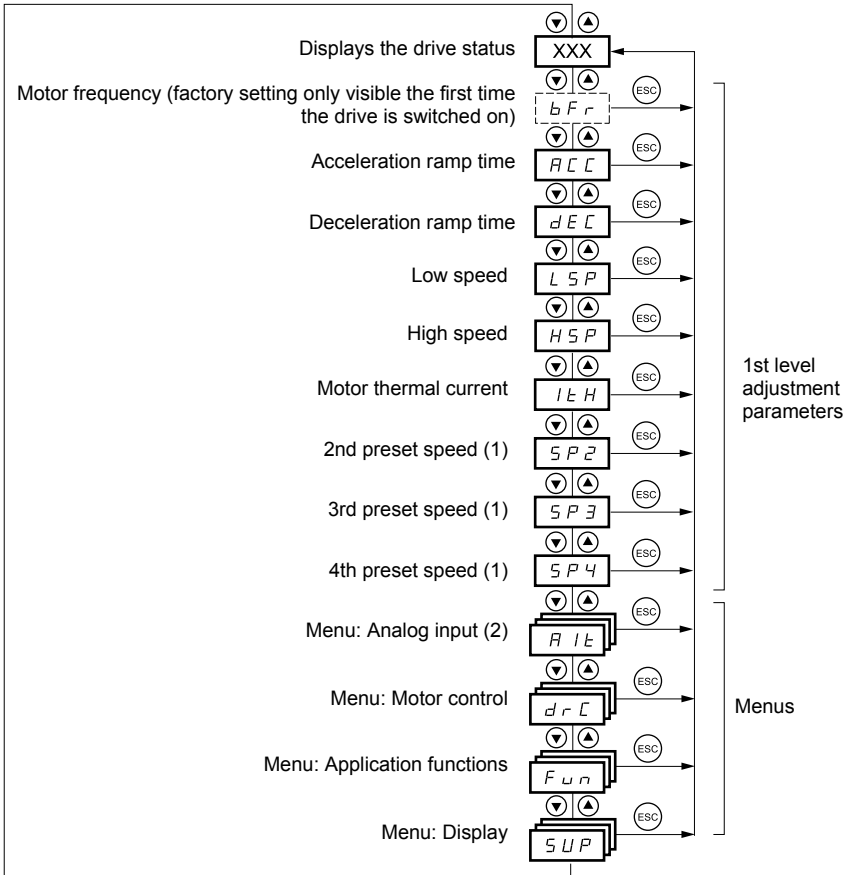

(1) The preset speeds only appear if the corresponding function has remained at the factory setting or has been reconfigured in the FUn menu.

(2) New menu in version V1.2, replacing 1st level adjustment parameter Alt in version V1.1.

# 1st level adjustment parameters

## Access to parameters

**Save and store the selection:** 

The display flashes when a value is stored.

Example:

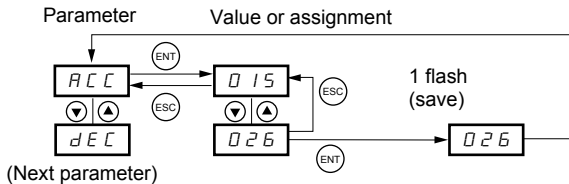

(Next parameter)

 The parameters in clear boxes can only be modified when the drive is stopped and locked.

 Parameters in shaded boxes can be modified with the drive operating or stopped.

Code	Description	Adjustment range	Factory setting
<b>b F r</b>	<b>Motor frequency</b>	50 Hz or 60 Hz	50 (E and A ranges) or 60 (U range)
	This parameter is only visible the first time the drive is switched on. It can be modified at any time in the FUn menu.		
<b>R C L</b>	<b>Acceleration ramp time</b>	0.1 s to 99.9 s	3
	Range: 0 Hz to motor nominal frequency FrS (parameter in drC menu).		
<b>d E C</b>	<b>Deceleration ramp time</b>	0.1 s to 99.9 s	3
	Range: motor nominal frequency FrS (parameter in drC menu) to 0 Hz.		
<b>L S P</b>	<b>Low speed</b>	0 Hz to HSP	0
	Motor frequency at min. reference.		
<b>H S P</b>	<b>High speed</b>	LSP to 200 Hz	= bFr
	Motor frequency at max. reference. Check that this setting is appropriate for the motor and the application.		
<b>I L H</b>	<b>Motor thermal current</b>	0 to 1.5 In (1)	According to drive rating
	Current used for the motor thermal protection. Set ItH to the nominal current on the motor rating plate.		
<b>S P 2</b>	<b>2nd preset speed (2)</b>	0.0 Hz to HSP	10
<b>S P 3</b>	<b>3rd preset speed (2)</b>	0.0 Hz to HSP	25
<b>S P 4</b>	<b>4th preset speed (2)</b>	0.0 Hz to HSP	50

(1) In = nominal drive current

(2) The preset speeds only appear if the corresponding function has remained at the factory setting or has been reconfigured in the FUn menu.

# Analog input menu Alt

New menu in version V1.2.

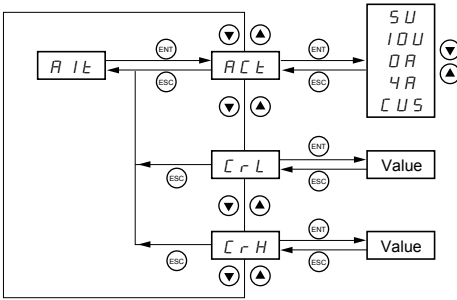

These parameters can only be modified when the drive is stopped and locked.

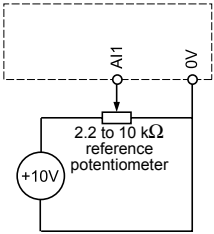
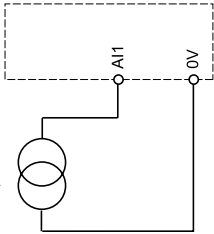
Code	Description	Adjustment range	Factory setting
<b>ACt</b>	<p><b>Scale of analog input AI1</b></p> <p><b>5U</b>: voltage 0-5 V (internal power supply only)  <b>10U</b>: voltage 0 - 10 V (external power supply)  <b>0A</b>: current 0 - 20 mA  <b>4A</b>: current 4 - 20 mA  <b>CUS</b>: current X - Y mA (customised)</p> <p>If CUS is activated, CrL (X) and CrH (Y) must be configured. These 2 parameters are used to define the signal sent to AI1. It is possible to configure the input for a 0-20 mA, 4-20 mA signal, etc.</p> <p style="text-align: center;">Analog input Use with external 10 V</p>  <p style="text-align: center;">Analog input 0 - 20 or 4 - 20 mA</p> 		"5U"
<b>CrL</b>	<p><b>Minimum value of the signal on input AI1</b></p> <p>Appears if CUS has been activated. AI1 min reference in mA. (CrL &lt; CrH)</p>	0 to 20.0	4.0
<b>CrH</b>	<p><b>Maximum value of the signal on input AI1</b></p> <p>Appears if CUS has been activated. AI1 max reference in mA. (CrH &gt; CrL)</p>	0 to 20.0	20.0

# Motor control menu drC

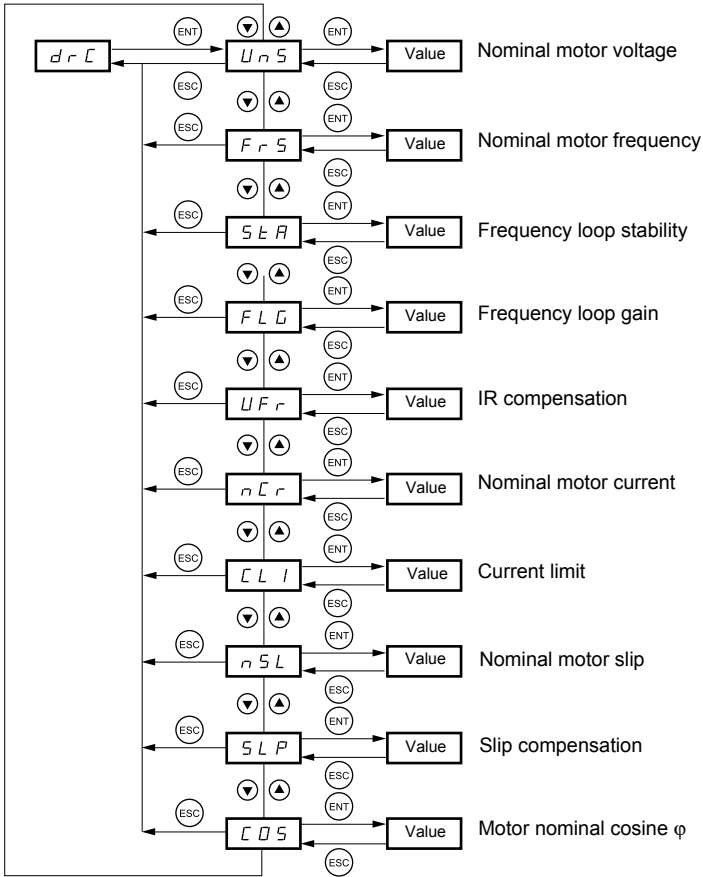

ENGLISH

# Motor control menu drC

The parameters in clear boxes can only be modified when the drive is stopped and locked.

Parameters in shaded boxes can be modified with the drive operating or stopped.

Drive performance can be optimized by entering the values marked on the motor rating plate.

Code	Description	Adjustment range	Factory setting
<i>U<sub>n</sub>S</i>	<b>Nominal motor voltage given on the rating plate</b> If the line voltage is less than the rated motor voltage, U <sub>n</sub> S should be set to the value of the line voltage applied to the drive terminals.	100 to 500 V	Acc. to rating
<i>F<sub>r</sub>S</i>	<b>Nominal motor frequency given on the rating plate</b>	40 to 200 Hz	50/60Hz dep. on bFr
<i>S<sub>L</sub>R</i>	<b>Frequency loop stability (2)</b> Too high a value causes an extended response time. Too low a value causes an overspeed, or even instability.	0 to 100% when stopped 1 to 100% when running	20
<i>F<sub>L</sub>G</i>	<b>Frequency loop stability (2)</b> Too high a value causes an overspeed, or even instability. Too low a value causes an extended response time.	0 to 100% when stopped 1 to 100% when running	20
<i>U<sub>F</sub>r</i>	<b>IR compensation</b> Used to optimize the torque at very low speed, or to adapt to special cases (example: for motors connected in parallel, lower U <sub>F</sub> r). If there is insufficient torque at low speed, increase U <sub>F</sub> r. Too high a value can cause the motor not to start (locking) or a change to current limit mode.	0 to 200%	50
<i>n<sub>L</sub>r</i>	<b>Nominal motor current given on the rating plate.</b>	0.25 to 1.5 I <sub>n</sub> (1)	Acc. to rating
<i>L<sub>L</sub>I</i>	<b>Current limit</b>	0.5 to 1.5 I <sub>n</sub> (1)	1.5 I <sub>n</sub>

(1) I<sub>n</sub> = nominal drive current

(2) Procedure on attached page

## Procedure for adjusting the speed loop - FLG and StA:

Occasions when the FLG and StA settings need to be reviewed:

- application with high inertia
- need for short reaction time, fast cycles
- unbalanced load

### FLG:

The FLG parameter adjusts the slope of the speed increase according to the inertia of the machine being driven.

Zone affected by the FLG parameter

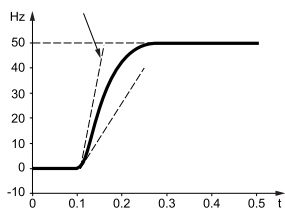

In this case, increase FLG

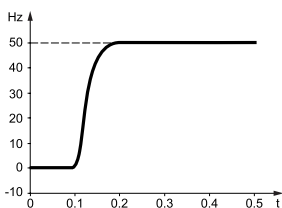

FLG correct

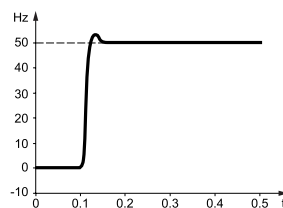

In this case, reduce FLG

### StA:

The StA parameter can be used to reduce overshoots and oscillations at the end of acceleration.

Zone affected by the StA parameter

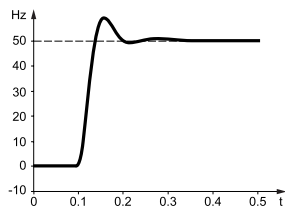

In this case, increase StA

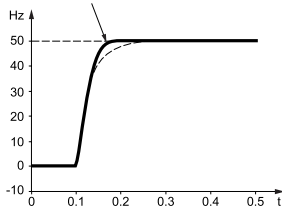

StA correct

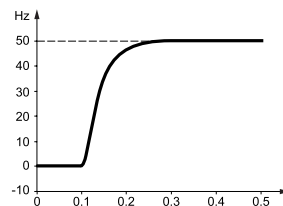

In this case, reduce StA

### Notes:

When FLG = 0 or StA = 0, there is a change of control profile: change from a sensorless flux vector control profile to V/F type control (identical to the ATV08 control profile).

Because of this, the UFr, FLG and StA settings will differ from the ATV08 on the same application.

# Motor control menu drC

The parameters in clear boxes can only be modified when the drive is stopped and locked.

Parameters in shaded boxes can be modified with the drive operating or stopped.

Code	Description	Adjustment range	Factory setting
n 5 L	<p><b>Nominal motor slip</b> Calculate using the formula:</p> $nSL = \text{parameter FrS} \times \frac{N_s - N_n}{N_s}$ <p><math>N_n</math> = nominal motor speed given on the rating plate <math>N_s</math> = motor synchronous speed</p> <p>The slip and speeds given on motor rating plates are not necessarily exact.</p> <ul style="list-style-type: none"> <li>• If the slip setting is lower than the actual slip: the motor is not rotating at the correct speed.</li> <li>• If the slip setting is higher than the actual slip: the motor is overcompensated and the speed is unstable.</li> </ul> <p>In both cases, the SLP setting needs to be reviewed (slip compensation).</p>	0 to 10.0 Hz	Acc. to rating
5 L P	<p><b>Slip compensation</b> Used to adjust the slip compensation around the value set by the nominal motor slip nSL, or to adapt to special cases (example: for motors connected in parallel, lower SLP).</p>	0 to 150% (of nSL)	100
C 0 5	<p><b>Nominal motor cosine <math>\varphi</math> given on the rating plate</b></p>	0.50 to 1.00	Acc. to rating



# Application functions menu FUN

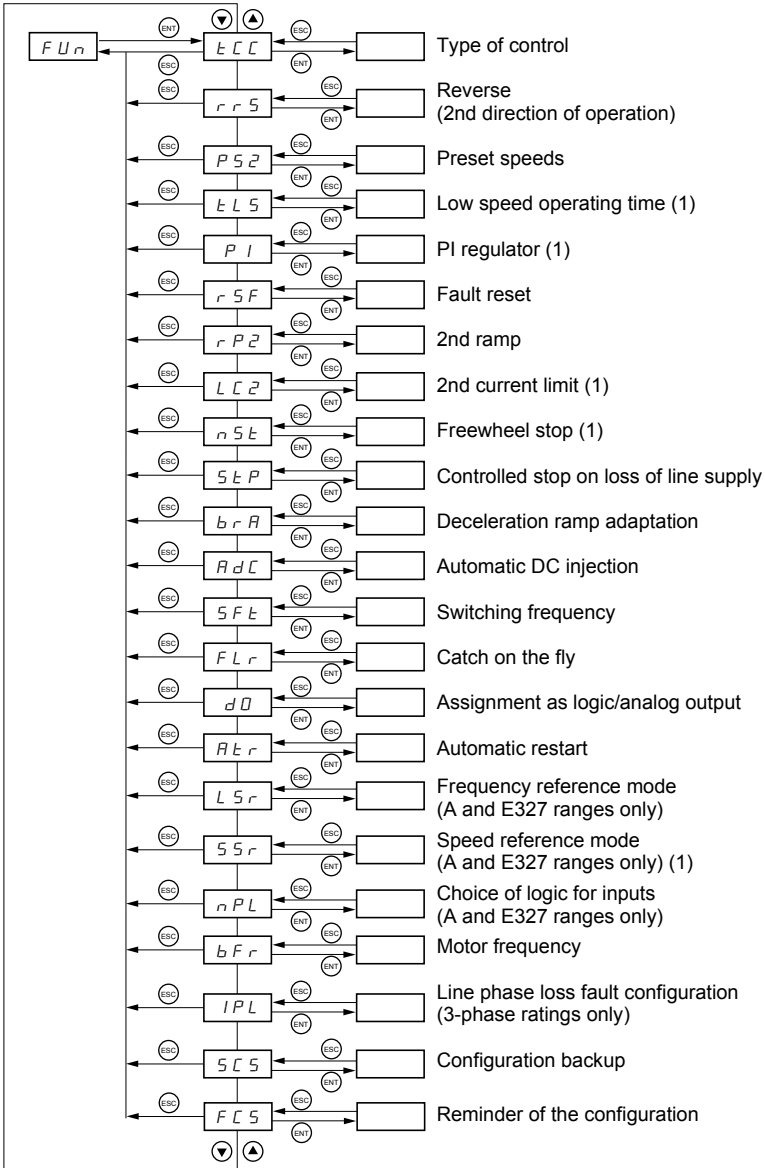

(1) New parameters in version V1.2.

## Caution



Several functions can be assigned to one input. This means that if one input is activated, all the functions assigned to this input are activated together.

## Incompatible functions

The following functions will be inaccessible or deactivated in the cases described below:

### Automatic restart

This is only possible for 2-wire level detection control (tCC = 2C and tCt = LEL or PFO). A change in the type of control after configuring automatic restarts deactivates the function.

### Catch on the fly

This is only possible for 2-wire level detection control (tCC = 2C and tCt = LEL or PFO). A change in the type of control after configuring flying restarts deactivates the function.

This function is locked if automatic injection on stopping is configured as DC (AdC = Ct).



Switching to Ct after configuring flying restarts deactivates the function.

### Reverse

On the A and E327 ranges only, this function is locked if local control is active (tCC = LOC).

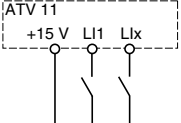
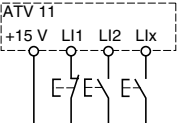

# Application functions menu FUN

Function code	Description	Factory setting
<p><i>ECC</i></p> <p><i>ACE</i></p>	<p><b>Type of control</b>            Configuration of control:  <i>2C</i> = 2-wire control  <i>3C</i> = 3-wire control  <i>LOC</i> = local control (drive RUN/STOP) for the A and E327 ranges only.</p> <p>2-wire control: The open or closed state of the input controls the running or stopping.</p> <p>Wiring example:</p>  <p>LI1: forward            LIx: reverse</p> <p>3-wire control (pulse control): a "forward" or "reverse" pulse is sufficient to command starting, a "stop" pulse is sufficient to command stopping.</p> <p>Example of wiring:</p>  <p>LI1: stop            LI2: forward            LIx: reverse</p> <p> To change the assignment of tCC press the "ENT" key for 2 s. This causes the following functions to return to their factory setting: rrS, tCt, Atr, PS2 (LIA, LIb).</p>	<p>E and U ranges:            2C            A and E327 ranges:            LOC</p>
<p><i>ECE</i></p>	<p>2-wire type control            (parameter can only be accessed if tCC = 2C):  <i>LEL</i>: state 0 or 1 is taken into account for run or stop.  <i>En</i>: a change of state (transition or edge) is necessary to initiate operation, in order to prevent accidental restarts after a power supply interruption.  <i>PFQ</i>: state 0 or 1 is taken into account for run or stop, but the "forward" input always takes priority over the "reverse" input.</p>	<p>trn</p>

ENGLISH

# Application functions menu FUn

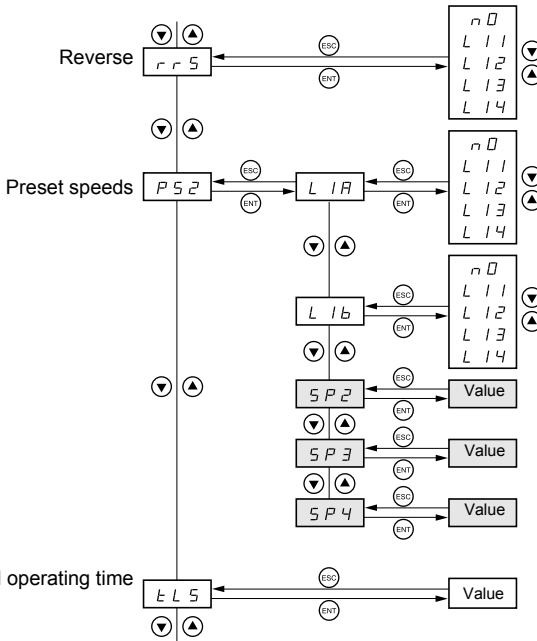

ENGLISH

The parameters in clear boxes can only be modified when the drive is stopped and locked.

Parameters in shaded boxes can be modified with the drive operating or stopped.

# Application functions menu FUN

## Preset speeds

2 or 4 speeds can be preset, requiring 1 or 2 logic inputs respectively.  
The following assignment order must be observed: LIA (Llx), then Llb (Lly).

2 preset speeds		4 preset speeds		
Assign: Llx to LIA		Assign: Llx to LIA, then Lly to Llb		
Llx	speed reference	Lly	Llx	speed reference
0	reference (min. = LSP)	0	0	reference (min. = LSP)
1	SP2	0	1	SP2
		1	0	SP3
		1	1	SP4

The preset speeds take priority over the reference given by the analog input or by the drive potentiometer (A and E327 ranges).

Function code	Description	Factory setting
<b>rr5</b>	<b>Reverse</b> - <b>nD</b> : function inactive - <b>L11</b> to <b>L14</b> : choice of the input assigned to the reverse command. If tCC = LOC, this parameter is inaccessible. If PIF = AI1 (page 107), rrS is forced to nO.	if tCC = 2C: LI2 if tCC = 3C: LI3
<b>P52</b>	<b>Preset speeds</b> If LIA and Llb = 0: speed = reference If LIA = 1 and Llb = 0: speed = SP2 If LIA = 0 and Llb = 1: speed = SP3 If LIA = 1 and Llb = 1: speed = SP4 On ATV31●●E and U, if the PI function is configured (PIF = AI1 see page 107), LIA is forced to LI1. The preset speeds remain active on the A and E327 ranges <b>even in local control mode</b> (tCC and/or LSr = LOC).  <b>L1A</b> Assignment of input LIA - <b>nD</b> : function inactive - <b>L11</b> to <b>L14</b> : choice of the input assigned to LIA  <b>L1b</b> Assignment of input Llb - <b>nD</b> : function inactive - <b>L11</b> to <b>L14</b> : choice of the input assigned to Llb  SP2 is only accessible if LIA is assigned, SP3 and SP4 if LIA and Llb are assigned.	if tCC = 2C: LI3 if tCC = 3C: LI4 if tCC = LOC: LI3  if tCC = 2C: LI4 if tCC = 3C: nO if tCC = LOC: LI4
<b>SP2</b>	2nd preset speed, adjustable from 0.0 Hz to HSP (1)	10
<b>SP3</b>	3rd preset speed, adjustable from 0.0 Hz to HSP (1)	25
<b>SP4</b>	4th preset speed, adjustable from 0.0 Hz to HSP (1)	50
<b>LLS</b>	<b>Low speed operating time</b> Can be adjusted from 0 to 999 seconds. Following operation at LSP for a defined period, a motor stop is requested automatically. The motor restarts if the frequency reference is greater than LSP and if a run command is still present. Caution: Value 0 corresponds to an unlimited period.	0 (no time limit)

(1) The preset speed settings can also be accessed in the 1st level adjustment parameters.

# Application functions menu FUn

## PI regulator

The PI regulator is used to regulate a process (level, pressure, etc) that is controlled by the speed of the motor with a speed reference and feedback given by a sensor.

### Operating conditions

- The speed reference can be provided by one of the following:
  - an internal reference (rPI) which is a percentage (from 0.1% to 100%) of the HSP maximum frequency reference (for all ranges).
  - a speed reference (AIP) given by the potentiometer on the front panel for the ATV11 A and E327 ranges.
  - 3 preset references (PI2, PI3 and PI4) via logic inputs, which take priority over the 2 previous methods.
- The sensor feedback is connected to analog input AI1. Analog input AI1 is configured in the Alt menu.
- The PI function is programmed via the PI sub-menu in the FUn function menu.
- The following parameters are used to configure the PI function:
  - **P I F** = Assignment of the feedback for the PI function
  - **P I I** = Choice of the internal speed reference
  - **r P I** = PI internal reference
  - **r P G** = PI regulator proportional gain
  - **r I G** = PI regulator integral gain
  - **F b S** = PI feedback scale factor
  - **P I C** = PI error inversion
  - **P r 2** = 2 preset PI references via logic input
  - **P r 4** = 4 preset PI references via logic inputs
  - **P I 2** = 2nd preset PI reference
  - **P I 3** = 3rd preset PI reference
  - **P I 4** = 4th preset PI reference

**Note:** The 1st preset reference is:

- rPI in the E and U ranges
- rPI or AIP (reference given by the potentiometer) in the A and E327 ranges.

Pr2		Pr4		
Llx	Speed reference	Lly	Llx	Speed reference
0	rPI or AIP (A and E327 ranges)	0	0	rPI or AIP (A and E327 ranges)
1	PI2	0	1	PI2
		1	1	PI3
		1	0	PI4

**Notes:**

**In the A and E327 ranges, the PI function is not accessible in the factory settings. First deactivate local control and then change to 2-wire control (tCC/ACT = 2C see page 99).**

When the PI function is activated (PIF = AI1):

- rrS is forced to nO.
- In the A and E327 ranges, LSr is forced to LOC (speed reference given by the potentiometer).
- Logic output DO can be assigned to the PI function. When the PI regulator is operational, the output changes to logic state 1.
- In the E and U ranges the PS2 preset speeds function is automatically assigned to LIA = LI1 (see page 101)

# Application functions menu FUn

## "Manual - Automatic" operation with PI

This function assigns parameter PAU to a logic input, enabling the user to select between a reference given by the PI regulator function (automatic operation) and a reference (manual operation) which is set either by the potentiometer (A and E327 ranges) or by preset speed SP2 (E and U ranges).

**Note:** With the E and U ranges, a second preset speed, SP4, can be obtained by assigning a logic input to LIB in PS2 (with LI1 still at 1).

During manual operation, the reference value at the PI regulator output not active at the time is automatically adjusted to the same value as the manual reference so that when the user switches to automatic operation, the difference between the 2 references is as small as possible, in order to limit any jolts.

PAU	Operation	Reference
0	Manual	AIP (A and E327 ranges) SP2 (E & U ranges)
1	Automatic	PI regulator output

## Methodology for configuring the PI function

	Operat.Type	Menu	Pages
1	Configuration of analog input AI1 (sensor feedback)	Alt	90
2	Configuration of the parameters required for the PI function	FUn	106
3	(Optional) Configuration of the parameters for low speed operating time (tLS) and minimum error threshold for restart (rSL).	FUn	101 and 107

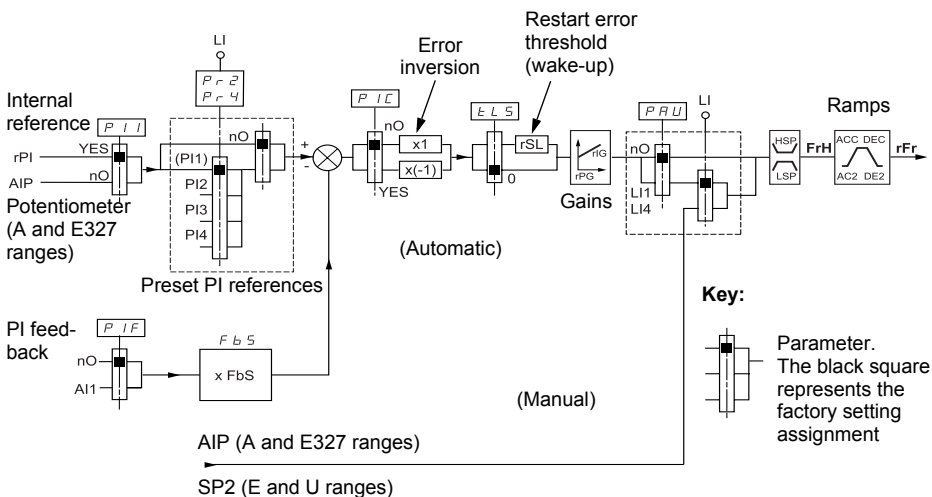

## Setting up the PI regulator

### 1 Perform a test in factory settings mode (in most cases, this will be sufficient).

To optimize the drive, adjust rPG or rIG gradually and independently and observe the effect on the PI feedback and the reference.

### 2 If the factory settings are unstable or the reference is incorrect:

Perform a test with a speed reference in Manual mode (without PI regulator) and with the drive on load for the speed range of the system:

- In steady state, the speed must be stable and comply with the reference and the PI feedback signal must be stable.

- In transient state, the speed must follow the ramp and stabilize quickly and the PI feedback must follow the speed.

If this is not the case, see the settings for the drive and/or sensor signal and wiring.

Switch to PI mode.

Set the speed ramps (ACC, dEC) to the minimum permitted by the mechanism without triggering a fault.

Set the integral gain (rIG) to minimum.

Observe the PI feedback and the reference.

Switch the drive ON/OFF a number of times or vary the load or reference rapidly.

Set the proportional gain (rPG) in order to ascertain the ideal compromise between response time and stability in transient phases (slight overshoot and 1 to 2 oscillations max. before stabilizing).

If the reference varies from the preset value in steady state, gradually increase the integral gain (rIG), reduce the proportional gain (rPG) in the event of instability (hunting), find a compromise between response time and static precision (see diagram on next page).

Perform in-production tests over the whole reference range.

# Application functions menu FUn

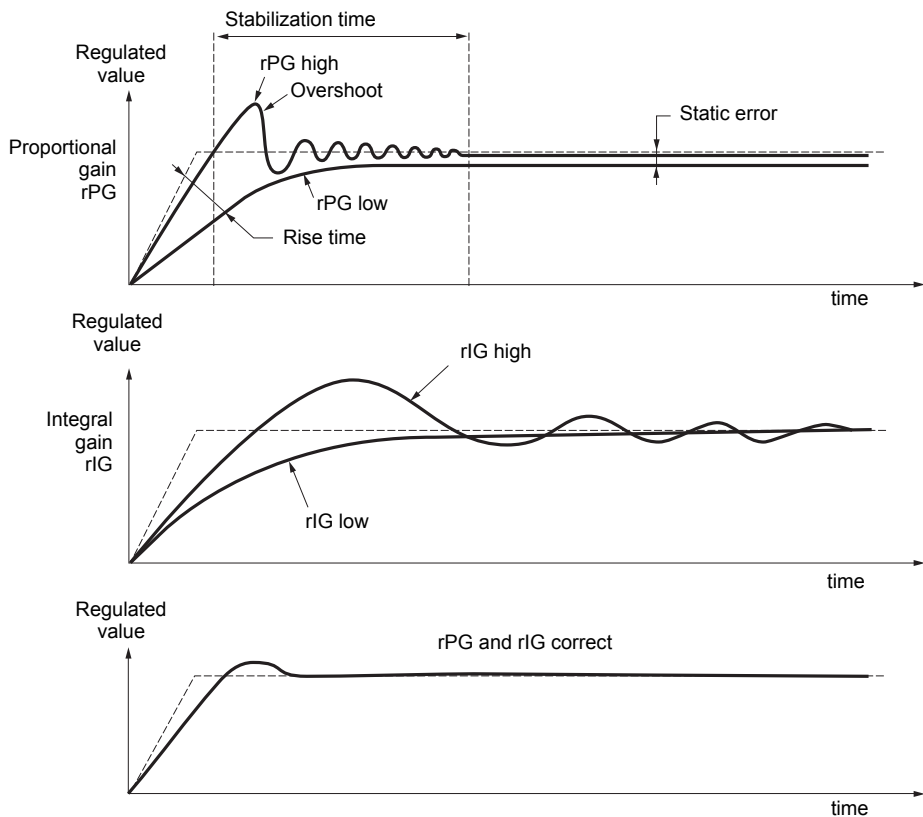

ENGLISH

The oscillation frequency depends on the system kinematics.

Influence of parameters:

Parameter	Rise time	Overshoot	Stabilization time	Static error
rPG	↗	↘ ↘	=	↘
rIG	↗	↘	↗	↘ ↘

# Application functions menu FUN

## PI sub-menu

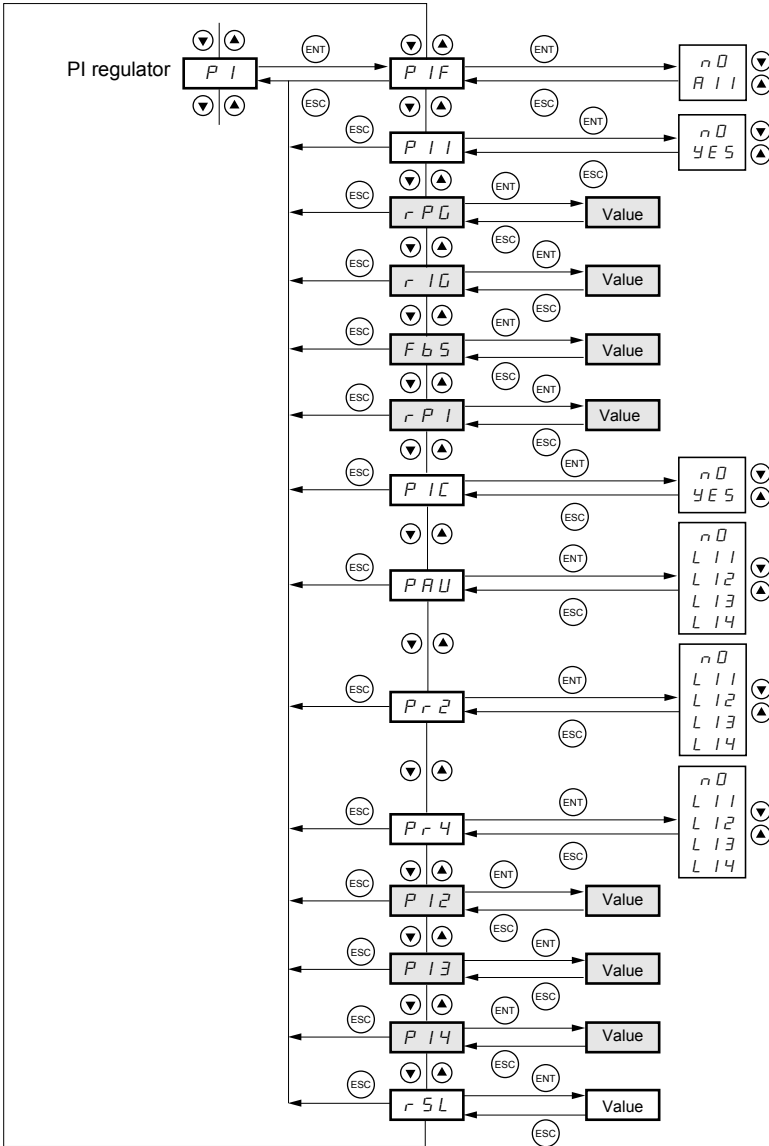

The parameters in clear boxes can only be modified when the drive is stopped and locked.

Parameters in shaded boxes can be modified with the drive operating or stopped.

# Application functions menu FUn

Function code	Description	Adjustment range	Factory setting
<i>P 1 F</i>	<b>Assignment of the PI function feedback</b> <i>n 0</i> : Not assigned (PI function inactive) <i>F 1 1</i> : Analog input AI1 (PI function activated)		n0
<i>P 1 1</i>	<b>Activation of the choice of internal speed reference</b> <i>n 0</i> : AIP if A and E327 ranges only (reference by potentiometer) <i>Y E S</i> : rPI PII = n0 is only visible on the A and E327 ranges		YES
<i>r P G</i>	<b>PI regulator proportional gain</b>	0 to 9.99	1
<i>r I G</i>	<b>PI regulator integral gain</b>	0 to 9.99	1
<i>F b 5</i>	<b>PI feedback scale factor</b> PI feedback multiplication coefficient. This is used to adjust the maximum value of the feedback so that it corresponds to the maximum value of the PI regulator reference.	0.01 to 100	1
<i>r P I</i>	<b>PI internal reference</b>	0 to 100%	0
<i>P 1 C</i>	<b>PI error inversion</b> <i>n 0</i> : No <i>Y E S</i> : Yes		n0
<i>P R U</i>	<b>Automatic-manual (switching of references)</b> <i>n 0</i> : Not assigned <i>L 1 1</i> to <i>L 1 4</i> : Choice of assigned logic input Automatic operation is enabled with the input at state 1.		n0
<i>P r 2</i>	<b>2 preset PI references by assignment of LI.</b> <i>n 0</i> : Not assigned <i>L 1 1</i> to <i>L 1 4</i> : Choice of assigned logic input		n0
<i>P r 4</i>	<b>4 preset PI references by assignment of LI.</b> Pr2 must be assigned before assigning Pr4. <i>n 0</i> : Not assigned <i>L 1 1</i> to <i>L 1 4</i> : Choice of assigned logic input		n0
<i>P 1 2</i>	<b>2nd preset PI reference</b>	0 to 100%	30
<i>P 1 3</i>	<b>3rd preset PI reference</b>	0 to 100%	60
<i>P 1 4</i>	<b>4th preset PI reference</b>	0 to 100%	90
<i>r 5 L</i>	<b>Restart error threshold.</b> If the "PI" and "Low speed operating time" (tLS) functions are configured at the same time, the PI regulator may attempt to set a speed lower than LSP. This results in unsatisfactory operation which consists of starting, operating at low speed then stopping, and so on.... Parameter rSL (restart error threshold) can be used to set a minimum PI error threshold for restarting after a stop on "prolonged LSP". Visible only if tLS > 0 and PI function activated.	0 to 999 (999 = 99.9% error)	0

# Application functions menu FUn

ENGLISH

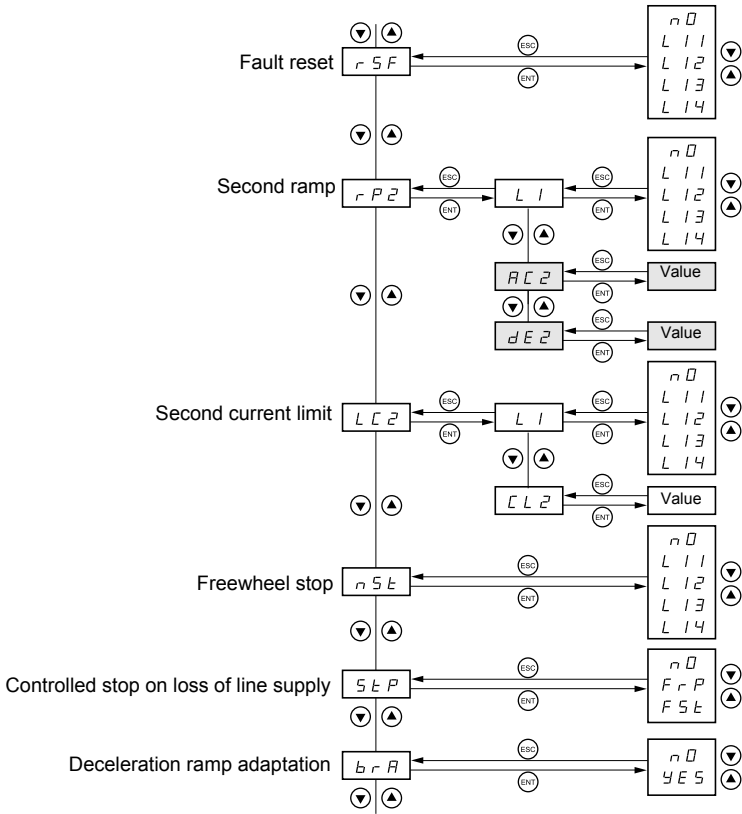

The parameters in clear boxes can only be modified when the drive is stopped and locked.

Parameters in shaded boxes can be modified with the drive operating or stopped.

# Application functions menu FUn

Function code	Description	Factory setting
<i>r S F</i>	<b>Fault reset</b> - <i>n O</i> : function inactive - <i>L 1 1</i> to <i>L 1 4</i> : choice of the input assigned to this function The reset occurs on the input transition (rising edge 0 to 1). Clears the memorized fault and resets the drive if the cause of the fault has disappeared, except for OCF (overcurrent), SCF (motor short-circuit), and InF (internal fault) faults, which require the drive to be disconnected.	n0
<i>r P 2</i> <i>L 1</i>	<b>Second ramp</b> Assignment of the 2nd ramp control input - <i>n O</i> : function inactive - <i>L 1 1</i> to <i>L 1 4</i> : choice of assigned input  AC2 and dE2 are only accessible if LI is assigned.	n0
<i>A C 2</i>	2nd acceleration ramp time, adjustable from 0.1 to 99.9 s	5.0
<i>d E 2</i>	2nd deceleration ramp time, adjustable from 0.1 to 99.9 s	5.0
<i>L C 2</i> <i>L 1</i>	<b>Second current limit</b> Function active when the input is powered up. - <i>n O</i> : function inactive - <i>L 1 1</i> to <i>L 1 4</i> : choice of assigned input. If the input is at 0: 1st current limit CL1 If the input is at 1: 2nd current limit CL2	n0
<i>C L 2</i>	Value for 2nd current limit. CL2 is only accessible if LI is assigned.	1.5 In (1)
<i>n S t</i>	<b>Freewheel stop</b> - <i>n O</i> : function inactive - <i>L 1 1</i> to <i>L 1 4</i> : choice of assigned input. Stop when the input is unconnected (state 0), ie. contact open. Causes the motor to stop using the resistive torque only. The supply to the motor is removed.	n0
<i>S t P</i>	<b>Controlled stop on loss of line supply</b> - <i>n O</i> : locking of the drive and freewheel stopping of the motor - <i>F r P</i> : stop according to the valid ramp (dEC or dE2). The machine inertia must be sufficient to follow the ramp. - <i>F S t</i> : fast stop, the stopping time depends on the inertia and the braking ability of the drive.	n0
<i>b r A</i>	<b>Deceleration ramp adaptation</b> - <i>n O</i> : function inactive - <i>Y E S</i> : This function can be used to increase the deceleration time automatically, if this has been set at too low a value for the inertia of the load, thus avoiding the drive developing an overvoltage fault. This function may be incompatible with positioning on a ramp. It should only be deactivated when an appropriate braking resistor and module are being used.	YES

(1) In: nominal drive current

# Application functions menu FUn

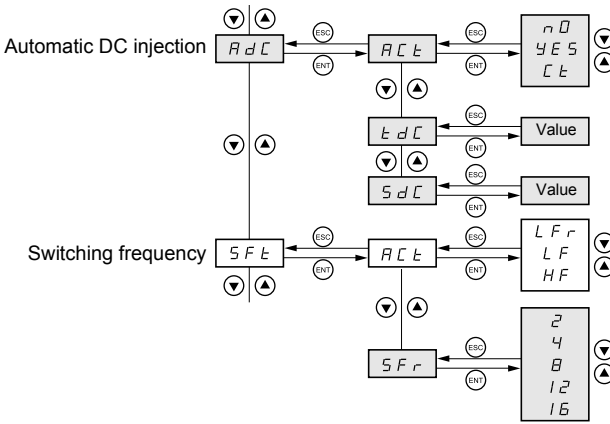

ENGLISH

The parameters in clear boxes can only be modified when the drive is stopped and locked.

Parameters in shaded boxes can be modified with the drive operating or stopped.

# Application functions menu FUn

Function code	Description	Factory setting
<b>A d C</b> <i>A C t</i>	<p><b>Automatic DC injection</b> Operating mode</p> <ul style="list-style-type: none"> <li>- <b>n 0</b>: function inactive</li> <li>- <b>4 E 5</b>: automatic DC injection on stopping, duration adjustable via tdC, when operation is no longer controlled and the motor speed is zero. The value of this current can be adjusted via SdC.</li> <li>- <b>1 E</b>: Continuous DC injection on stopping, when operation is no longer controlled and the motor speed is zero. The value of this current can be adjusted via SdC.</li> </ul> <p>With 3-wire control, injection is only active when LI1 is at 1.</p> <p>tdC is only accessible if ACT = YES, SdC if ACT = YES or Ct.</p>	YES
<i>t d C</i>	Injection time on stopping, adjustable from 0.1 to 30.0 s	0.5
<i>S d C</i>	Injection current, adjustable from 0 to 1.2 In (In = nominal drive current)	0.7 In
<b>S F t</b> <i>A C t</i>	<p><b>Switching frequency</b> Frequency range</p> <ul style="list-style-type: none"> <li>- <b>L F r</b>: random frequency around 2 or 4 kHz according to SFr</li> <li>- <b>L F</b>: fixed frequency of 2 or 4 kHz according to SFr</li> <li>- <b>H F</b>: fixed frequency of 8, 12 or 16 kHz according to SFr</li> </ul>	LF
<i>S F r</i>	<p>Switching frequency:</p> <ul style="list-style-type: none"> <li>- <b>2</b>: 2 kHz (if ACT = LF or LFr)</li> <li>- <b>4</b>: 4 kHz (if ACT = LF or LFr)</li> <li>- <b>8</b>: 8 kHz (if ACT = HF)</li> <li>- <b>12</b>: 12 kHz (if ACT = HF)</li> <li>- <b>16</b>: 16 kHz (if ACT = HF)</li> </ul> <p>When SFr = 2 kHz, the frequency automatically changes to 4 kHz at high speed</p> <p>When SFt = HF, the selected frequency automatically changes to the lower frequency if the thermal state of the drive is too high. It automatically returns to the SFr frequency as soon as the thermal state permits.</p>	4 (if ACT = LF or LFr) 12 (if ACT = HF)

# Application functions menu FUn

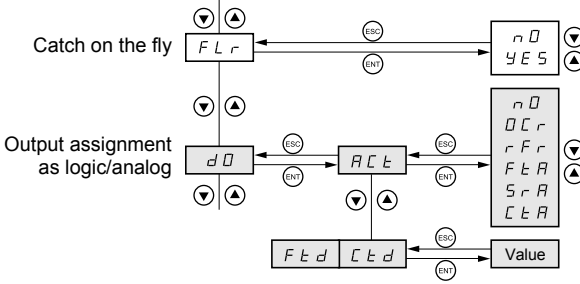

The parameters in clear boxes can only be modified when the drive is stopped and locked.

Parameters in shaded boxes can be modified with the drive operating or stopped.

# Application functions menu FUN

Function code	Description	Factory setting
<i>FLr</i>	<p><b>Catch on the fly</b>                      Used to enable a smooth restart if the run command is maintained after the following events:                      - loss of line supply or disconnection                      - fault reset or automatic restart                      - freewheel stop                      The speed given by the drive resumes from the estimated speed of the motor at the time of the restart, then follows the ramp to the reference speed.                      This function requires 2-wire control (tCC = 2C) with tCt = LEL or PFO.                      nD: function inactive                      YES: function active                      When the function is operational, it activates at each run command, resulting in a slight delay (1 second max.).                      If continuous automatic injection braking has been configured (Ct) this function cannot be activated.</p>	nO
<i>dD</i> <i>ACt</i>	<p><b>Analog/logic output DO</b>                      Assignment                      - nD: not assigned                      - DCr: analog output = current in the motor. The full signal corresponds to 200% of the nominal drive current.                      - rFr: analog output = motor frequency. The full signal corresponds to 100% HSP.                      - F t A: logic output = frequency threshold reached, closed (state 1) if the motor frequency exceeds the adjustable threshold Ftd.                      - S r A: logic output = reference reached, closed (state 1) if the motor frequency is equal to the reference.                      - C t A: logic output = current threshold reached, closed (state 1) closed if the motor current exceeds the adjustable threshold Ctd.                      - P I: logic output = PI running, closed (state 1) if the regulator is operating.                      Ftd is only accessible if ACt = FtA, Ctd is only accessible if ACt = CtA.</p>	rFr
<i>F t d</i> <i>C t d</i>	<p>frequency threshold, adjustable from 0 to 200 Hz                      current threshold, adjustable from 0 to 1.5 In (In = nominal drive current)</p>	= bFr In

## Use of the analog/logic output DO

Diagram with internal power supply:

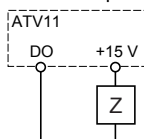
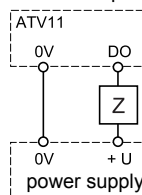

Diagram with external power supply:



If it is a logic output: Z = low-voltage relay or input.

If it is an analog output: Z = galvanometer for example. For a resistance galvanometer R,

the maximum voltage delivered will be:  $U \times \frac{R(\Omega)}{R(\Omega) + 1000(\Omega)}$

# Application functions menu FUn

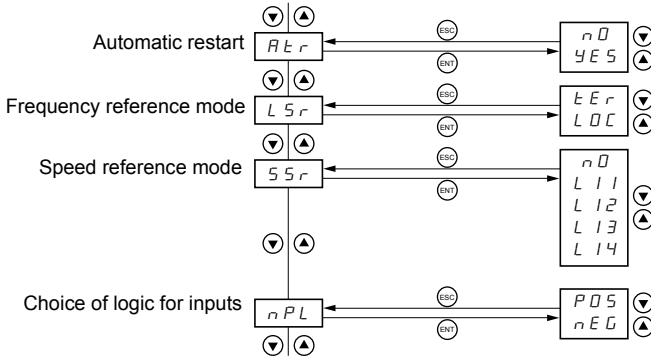





ENGLISH

The parameters in clear boxes can only be modified when the drive is stopped and locked.

Parameters in shaded boxes can be modified with the drive operating or stopped.

# Application functions menu FUN

Function code	Description	Factory setting
<i>tEr</i>	<p><b>Automatic restart</b></p> <ul style="list-style-type: none"> <li>- <i>nD</i>: function inactive</li> <li>- <i>YES</i>: Automatic restart, after locking on a fault, if the fault has disappeared and the other operating conditions permit the restart. The restart is performed by a series of automatic attempts separated by increasingly longer waiting periods: 1 s, 5 s, 10 s, then 1 min for the following periods. If the restart has not taken place after 6 min, the procedure is aborted and the drive remains locked until it is disconnected and then reconnected.</li> </ul> <p>The following faults permit this function: OHF, OLF, ObF, OSF, PHF. The drive fault relay remains activated if this function is active. The speed reference and the operating direction must be maintained. This function is only accessible with 2-wire control (tCC = 2C) with tCt = LEL or PFO.</p> <p> <b>Check that an accidental start does not present any danger to personnel or equipment.</b></p>	n0
<i>LSr</i>	<p><b>Frequency reference mode</b></p> <p>This parameter is only accessible on drives in the A and E327 ranges.</p> <ul style="list-style-type: none"> <li>- <i>LOC</i>: the speed reference is given by the potentiometer on the front of the drive.</li> <li>- <i>tEr</i>: the speed reference is given by analog input AI1.</li> </ul> <p> For LOC and tEr to be taken into account the ENT key must be held down for 2 s. If PIF = AI1 (page 107) LSr is forced to LOC.</p>	LOC
<i>SSr</i>	<p><b>Frequency switching (version V1.2)</b></p> <p>This parameter is only accessible on drives in the A and E327 ranges. Used to switch a reference via a logic input.</p> <ul style="list-style-type: none"> <li>- <i>nD</i>: Not assigned: the reference is given according to the configuration of LSr.</li> <li>- <i>L11</i>: Logic input LI1</li> <li>- <i>L12</i>: Logic input LI2</li> <li>- <i>L13</i>: Logic input LI3</li> <li>- <i>L14</i>: Logic input LI4</li> </ul> <p>Logic input at state 0: the reference is given by the potentiometer on the front panel of the drive. Logic input at state 1: the reference is given by analog input AI1</p> <p> <b>Caution: Switching via logic input is incompatible with the PI function.</b></p>	n0
<i>nPL</i>	<p><b>Choice of logic for inputs</b></p> <p>This parameter is only accessible on drives in the A and E327 ranges.</p> <ul style="list-style-type: none"> <li>- <i>PDS</i>: the inputs are active (state 1) at a voltage of 11 V or more (for example +15 V terminal) and inactive (state 0) when the drive is disconnected or at a voltage of less than 5 V.</li> <li>- <i>nEG</i>: the inputs are active (state 1) at a voltage of less than 5 V (for example 0 V terminal) and inactive (state 0) at a voltage of 11 V or more, or when the drive is disconnected.</li> </ul> <p> For PoS and nEG to be taken into account the ENT key must be held down for 2 s.</p>	

# Application functions menu FUn

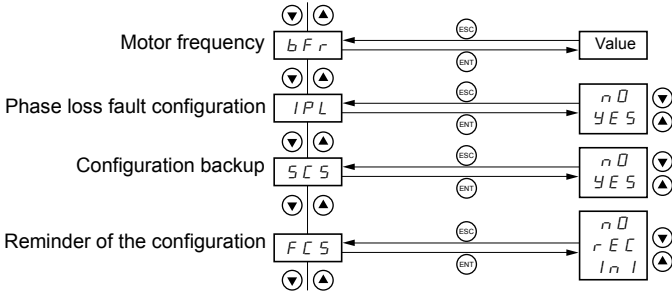

ENGLISH

The parameters in clear boxes can only be modified when the drive is stopped and locked.

Parameters in shaded boxes can be modified with the drive operating or stopped.

# Application functions menu FUn

Function code	Description	Factory setting
<i>bFr</i>	<b>Motor frequency</b> (Same as bFr 1st level adjustment parameter) Set to 50 Hz or 60 Hz, taken from the motor rating plate.	50 (E and A ranges) or 60 (U range)
<i>IPL</i>	<b>Line phase loss fault configuration</b> This parameter is only accessible on 3-phase drives. - <i>nD</i> : inhibition of the line phase loss fault - <i>YES</i> : monitoring of the line phase loss fault	YES
<i>SCS</i>	<b>Configuration backup</b> - <i>nD</i> : function inactive - <i>YES</i> : saves the current configuration to the EEPROM memory. SCS automatically switches to nO as soon as save has been performed. This function is used to keep another configuration in reserve, in addition to the current configuration. When drives leave the factory the current configuration and the backup configuration are both initialized with the factory configuration.	nO
<i>FCS</i>	<b>Reminder of the configuration</b> - <i>nD</i> : function inactive - <i>rEC</i> : the current configuration becomes identical to the backup configuration previously saved by SCS. rEC is only visible if the backup has been carried out. FCS automatically changes to nO as soon as this action has been performed. - <i>InI</i> : the current configuration becomes identical to the factory setting. FCS automatically changes to nO as soon as this action has been performed.   For rEC and InI to be taken into account the ENT key must be held down for 2 s.	nO

# Display menu SUP

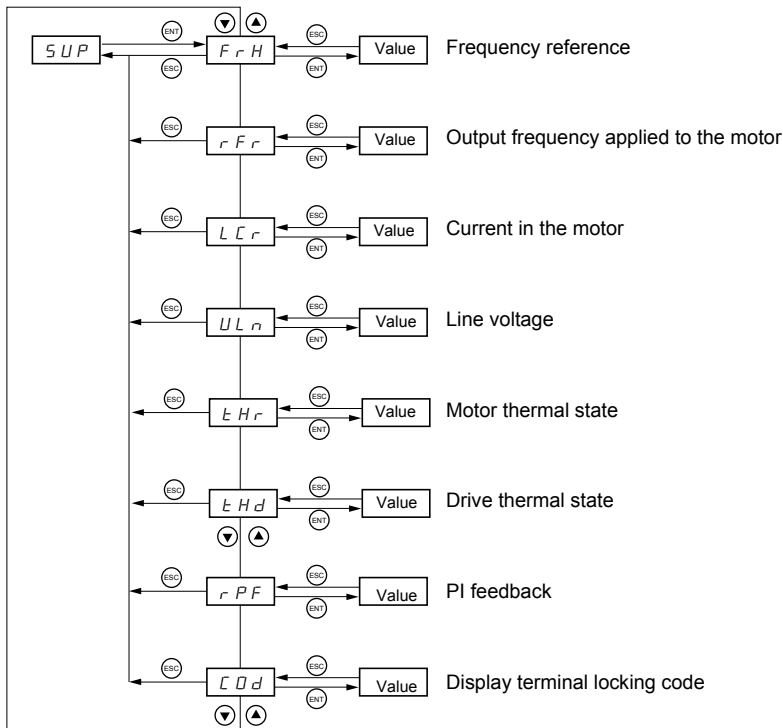

ENGLISH

When the drive is running, the value displayed is that of one of the monitoring parameters. The default value which is displayed is the motor reference (parameter FrH).

While the value of the desired new monitoring parameter is being displayed,

press a second time on the **ENT** button to confirm the change of monitoring parameter and store this. From now on, the value of this parameter will be displayed while the drive is running (even after it has been disconnected).

If the new selection is not confirmed by this second press on **ENT**, it will return to the previous parameter after the drive is disconnected.

# Display menu SUP

The following parameters can be accessed, with the drive stopped or running.

Code	Parameter	Unit
<i>F r H</i>	<b>Display of the frequency reference</b> (factory configuration)	Hz
<i>r F r</i>	<b>Display of the output frequency applied to the motor</b>	Hz
<i>L C r</i>	<b>Display of the motor current</b>	A
<i>U L n</i>	<b>Display of the line voltage</b>	V
<i>t H r</i>	<b>Display of the motor thermal state:</b> 100% corresponds to the nominal thermal state. Above 118%, the drive trips on an OLF fault (motor overload). It can be reset below 100%.	%
<i>t H d</i>	<b>Display of the drive thermal state:</b> 100% corresponds to the nominal thermal state. Above 118%, the drive triggers an OHF fault (drive overheating). It can be reset below 80%.	%
<i>r P F</i>	<b>PI sensor feedback</b> This parameter is only accessible if the PI function has been activated (PIF = A11).	%
<i>C D d</i>	<p><b>Display terminal locking code</b> Enables the drive configuration to be protected using an access code.</p> <p> <b>Caution: Before entering a code, do not forget to make a careful note of it.</b></p> <ul style="list-style-type: none"> <li>• <i>D F F</i>: No access locking codes. - <b>To lock access</b>, enter a code (2 to 999) (incrementing the display using ▲) and press "ENT". "On" appears on the display to indicate that the parameters have been locked.</li> <li>• <i>D n</i>: A code is locking access (2 to 999). - <b>To unlock access</b>, enter the security code (incrementing the display using ▲) and press "ENT". The code remains on the display and access is unlocked until the next power-down. Parameter access will be locked again on the next power-up. - If an incorrect code is entered, the display changes to "On" and the parameter remains locked.</li> </ul> <p><b>XXX</b>: Parameter access is unlocked (the code remains on the display). - <b>To reactivate locking with the same code</b> when parameter access has been unlocked, return to "On" using the ▼ button, then press "ENT". "On" remains on the screen to indicate that parameter access has been locked. - <b>To lock access with a new code</b> when parameter access has been unlocked, enter a new code (increment the display using ▲ or ▼) and press "ENT". "On" appears on the display to indicate that parameter access has been locked. - <b>To clear locking</b> when parameter access has been unlocked, return to "OFF", using the ▼ button and press "ENT". "OFF" remains on the display. Parameter access is unlocked and will remain unlocked until the next restart. When access is locked using a code, only the monitoring parameters are accessible.</p>	

# Maintenance

---

## Servicing

The Altivar 11 does not require any preventative maintenance. It is nevertheless advisable to perform the following regularly:

- Check the condition and tightness of connections.
- Ensure that the temperature around the unit remains at an acceptable level and that ventilation is effective (average service life of fans: 3 to 5 years depending on the operating conditions).
- Remove any dust from the drive.

## Assistance with maintenance, fault display

If a problem arises during setup or operation, ensure that the recommendations relating to the environment, mounting and connections have been observed.

The first fault detected is stored and displayed, flashing, on the screen: the drive locks and the fault relay (RA - RC) contact opens.

## Clearing the fault

Cut the power supply to the drive in the event of a non-resettable fault.

Wait for the display to go off completely.

Find the cause of the fault in order to correct it.

Restore the power supply: this clears the fault if it has disappeared.

In some cases there may be an automatic restart after the fault has disappeared, if this function has been programmed.

## Display menu

This is used to prevent and find the causes of faults by displaying the drive status and its current values.

## Spares and repairs

Consult Schneider Electric product support.

# Faults - Causes - Remedies

## Drive does not start, no fault displayed

- Check that the run command input(s) have been actuated in accordance with the chosen control mode (tCC parameter in the FUn menu).
- When the drive is switched on, or at a manual fault reset, or after a stop command, the motor can only be supplied with power once the "forward" and "reverse" commands have been reset. Otherwise, the drive will display "rdY" or "nSt" but will not start. If the automatic restart function has been configured (parameter Atr in the FUn menu), these commands are taken into account without a reset being necessary.
- If an input is assigned to the freewheel stop function, when this input is active at state 0 (not connected: open contact), it should be connected:
  - E and U ranges: to the + 15 V to allow the drive to start.
  - A and E327 ranges: to the + 15 V if nPL = POS or to the 0V if nPL = nEG to allow the drive to start (see nPL page 115).

## Drive does not start, display off

- Check that line voltage is present at the drive terminals.
- Unplug all the connections on the drive U, V, W terminals:
  - Check there is no short-circuit between a phase and earth in the motor wiring or in the motor.
  - Check that a braking resistor has not been connected directly to the PA/+ and PC/- terminals. Caution, if this is the case, it will certainly have damaged the drive. A braking module must always be used between the drive and the resistor.

## Faults which cannot be reset automatically

The cause of the fault must be removed before resetting by switching off and then on again. The SOF fault can also be reset via a logic input (rSF parameter in the FUn menu).

Fault	Probable cause	Remedy
<b>FFF</b> configuration fault	• The current configuration is inconsistent	• Return to factory settings or retrieve the backup configuration, if it is valid. See parameter FCS in the FUn menu.
<b>CrF</b> capacitor charging circuit	• load relay control fault or charging resistor damaged	• Replace the drive.
<b>Inf</b> internal fault	• internal fault	• Check the environment (electromagnetic compatibility). • Replace the drive.
<b>OCF</b> overcurrent	• ramp too short • inertia or load too high • mechanical locking	• Check the settings. • Check the size of the motor/drive/load. • Check the state of the mechanism.
<b>SCF</b> motor short-circuit	• insulation fault or short-circuit at the drive output	• Check the cables connecting the drive to the motor, and the motor insulation.
<b>SOF</b> overspeed	• instability or • driving load too high	• Check the motor, gain and stability parameters. • Add a braking resistor and module. • Check the size of the motor/drive/load.

# Faults - Causes - Remedies

## Faults which can be reset with the automatic restart function, after the cause has disappeared

These faults can also be reset by switching the drive off and on again or via a logic input (rSF parameter in the FUn menu)

Fault	Probable cause	Remedy
<b>ObF</b> overvoltage during deceleration	<ul style="list-style-type: none"><li>braking too sudden or driving load</li></ul>	<ul style="list-style-type: none"><li>Increase the deceleration time.</li><li>Install a braking module and a braking resistor if necessary.</li><li>Activate the brA function if it is compatible with the application.</li></ul>
<b>OHF</b> drive over temperature	<ul style="list-style-type: none"><li>drive temperature too high</li></ul>	<ul style="list-style-type: none"><li>Check the motor load, the drive ventilation and the environment. Wait for the drive to cool down before restarting.</li></ul>
<b>OLF</b> motor overload	<ul style="list-style-type: none"><li>triggered by motor current too high</li></ul>	<ul style="list-style-type: none"><li>Check the setting of the motor thermal protection, check the motor load. Wait for the motor to cool down before restarting.</li></ul>
<b>OSF</b> overvoltage	<ul style="list-style-type: none"><li>line voltage too high</li><li>disturbed line supply</li></ul>	<ul style="list-style-type: none"><li>Check the line voltage. The overvoltage threshold is 415 V <math>\overline{DC}</math> on the DC bus.</li></ul>
<b>PHF</b> line phase failure	<ul style="list-style-type: none"><li>drive incorrectly supplied or a fuse blown</li><li>failure of one phase</li><li>3-phase ATV11 used on a single-phase line supply</li><li>unbalanced load</li></ul> <p>This protection only operates with the drive on load.</p>	<ul style="list-style-type: none"><li>Check the power connection and the fuses.</li><li>Reset.</li><li>Use a 3-phase line supply.</li><li>disable the fault by setting IPL = nO (FUn menu)</li></ul>

## Fault which can be reset as soon as its cause disappears

Fault	Probable cause	Remedy
<b>USF</b> undervoltage	<ul style="list-style-type: none"><li>line supply too low</li><li>transient voltage dip</li><li>damaged load resistor</li></ul>	<ul style="list-style-type: none"><li>Check the voltage and the voltage parameter. The undervoltage threshold is 230 V <math>\overline{DC}</math> on the DC bus.</li><li>Replace the drive.</li></ul>

# Configuration/Settings Tables

Drive ATV11.....

Optional customer identification no: .....

1st level adjustment parameters

Code	Factory setting	Customer setting	Code	Factory setting	Customer setting
<b>b F r</b>	50/60 Hz	Hz	<b>l e H</b>	A	A
<b>R C C</b>	3 s	s	<b>S P 2</b>	10 Hz	Hz
<b>d e C</b>	3 s	s	<b>S P 3</b>	25 Hz	Hz
<b>L S P</b>	0 Hz	Hz	<b>S P 4</b>	50 Hz	Hz
<b>H S P</b>	50/60 Hz	Hz			

Analog input menu **A I E**

Code	Factory setting	Customer setting	Code	Factory setting	Customer setting
<b>R C E</b>	5U		<b>C r H</b>	20.0 mA	mA
<b>C r L</b>	4.0 mA	mA			

Motor control menu **d r C**

Code	Factory setting	Customer setting	Code	Factory setting	Customer setting
<b>U n S</b>	V	V	<b>n C r</b>	A	A
<b>F r S</b>	50/60 Hz	Hz	<b>C L I</b>	A	A
<b>S t R</b>	20 %	%	<b>n S L</b>	Hz	Hz
<b>F L G</b>	20 %	%	<b>S L P</b>	100 %	%
<b>U F r</b>	50 %	%	<b>C O S</b>		

# Configuration/Settings Tables

Application functions menu **FUn**

Code	Factory setting	Customer setting	Code	Factory setting	Customer setting
<i>ECC</i>			<i>rP2</i>		
<i>ACt</i>	2C/LOC		<i>L1</i>	nO	
<i>ECt</i>	trn		<i>AC2</i>	5 s	s
<i>rr5</i>	LI2		<i>dE2</i>	5 s	s
<i>PS2</i>			<i>LC2</i>		
<i>L1A</i>	LI3		<i>L1</i>	nO	
<i>L1b</i>	LI4		<i>CL2</i>	A	A
<i>SP2</i>	10 Hz	Hz	<i>nSt</i>	nO	
<i>SP3</i>	25 Hz	Hz	<i>StP</i>	nO	
<i>SP4</i>	50 Hz	Hz	<i>brA</i>	YES	
<i>EL5</i>	0 s	s	<i>AdC</i>		
<i>PI</i>			<i>ACt</i>	YES	
<i>PIF</i>	nO		<i>EdC</i>	0.5 s	s
<i>PII</i>	YES		<i>SdC</i>	A	A
<i>rPG</i>	1		<i>SFE</i>		
<i>rIG</i>	1		<i>ACt</i>	LF	
<i>FbS</i>	1		<i>SFr</i>	4 kHz	kHz
<i>rPI</i>	0 %	%	<i>FLr</i>	nO	
<i>PIC</i>	nO		<i>dD</i>		
<i>PAU</i>	nO		<i>ACt</i>	rFr	
<i>Pr2</i>	nO		<i>Ftd</i>	50/60 Hz	Hz
<i>Pr4</i>	nO		<i>Ctd</i>	A	A
<i>PI2</i>	30 %	%	<i>Retr</i>	nO	
<i>PI3</i>	60 %	%	<i>LSr(1)</i>	LOC	
<i>PI4</i>	90 %	%	<i>SSr(1)</i>	nO	
<i>rSL</i>	0		<i>nPL(1)</i>	POS	
<i>rSF</i>	nO		<i>bFr</i>	50/60 Hz	Hz
			<i>IPL</i>	YES	

(1) A and E327 ranges only