

Sololift+

Small lifting stations
50 Hz



Contents

Introduction

Applications	3
Product range	3
Function	3
Approvals	3

Sololift+ WC

Sololift+ WC	4
Applications	4
Examples of application	4
Pumped liquid	4
Features	4
Components	4
Technical data	4
Dimensions	5
Discharge pipe	5

Sololift+ WC-1

Sololift+ WC-1	6
Applications	6
Pumped liquid	6
Features	6
Components	6
Technical data	6
Dimensions	7
Discharge pipe	7

Sololift+ WC-3

Sololift+ WC-3	8
Applications	8
Pumped liquid	8
Features	8
Components	8
Technical data	8
Dimensions	9
Discharge pipe	9

Sololift+ CWC-3

Sololift+ CWC-3	10
Applications	10
Pumped liquid	10
Features	10
Components	10
Technical data	10
Dimensions	11
Discharge pipe	11

Sololift+ C-3

Sololift+ C-3	12
Applications	12
Pumped liquid	12
Features	12
Components	12
Technical data	12
Dimensions	13
Discharge pipe	13

Sololift+ D-3

Sololift+ D-3	14
Applications	14
Pumped liquid	14
Features	14
Components	14
Technical data	14
Dimensions	15
Discharge pipe	15

Further product documentation

WebCAPS	16
WinCAPS	17

Applications

Grundfos Sololift+ lifting stations are suitable for pumping of wastewater off places in private dwellings where the wastewater cannot be led directly to the main sewer by means of natural downward slope. The use of Sololift+ facilitates the installation of toilets, cabinet showers, washbasins or other facilities at basement, ground or loft level as it pumps the wastewater to the soil pipe.

Sololift+ gives the opportunity of installing facilities such as cabinet showers and toilets at a distance from the soil pipe without costly piping installations.

Sololift+ can be used for

- extra bathrooms
- basement installations
- low-cost bathrooms in holiday cottages
- added facilities in hotels and guesthouses
- bathrooms for the elderly or the disabled
- renovation of offices and other commercial buildings.

Examples of application

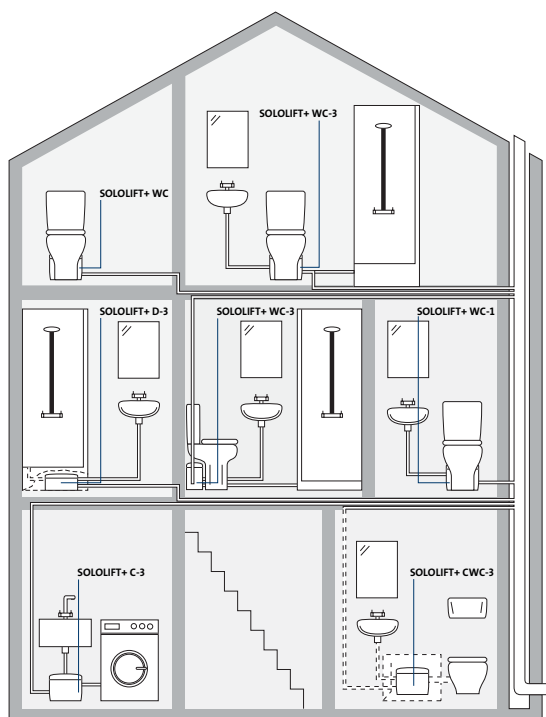

TM02 9562 3204

Product range

Type	Connection						
	Toilet	Wall-hung toilet	Washbasin	Cabinet shower	Bidet	Washing machine/ dish washer	Bath tub
Sololift+ WC Page 4	•						
Sololift+ WC-1 Page 6	•		•				
Sololift+ WC-3 Page 8	•		•	•	•		
Sololift+ CWC-3* Page 10			•	•	•	•	
Sololift+ C-3 Page 12				•	•	•	•
Sololift+ D-3 Page 14			•	•			

★ Maximum 70°C for two minutes.

Function

Wastewater from the units connected is led to the lifting station. The pump starts automatically when the liquid level reaches the start level, and stops when the level has fallen to the stop level. The start and stop levels depend of the type of Sololift+, see technical data of the individual types.

The tank of all Grundfos Sololift+ lifting stations is made of light plastic material with an easy-to-clean surface. Installed correctly, the Sololift+ works automatically and is maintenance-free.

Approvals



Sololift+ WC

Sololift+ WC is a small, compact automatic lifting station with integrated cutter system. It is suitable for pumping of wastewater off places in private dwellings where wastewater cannot be led directly to the sewer by means of a natural downward slope.

Applications

Sololift+ WC is typically used for:

- toilets in basements below sewer level and
- toilets installed in connection with the renovation or modernisation of existing buildings, where the location may be remote from the main soil pipe so that a natural slope cannot be established.

Sololift+ WC is suitable for pumping sewage water containing toilet paper and faeces. The pumping of liquids containing other material may cause faults and limit the scope of our guarantee.

Examples of application

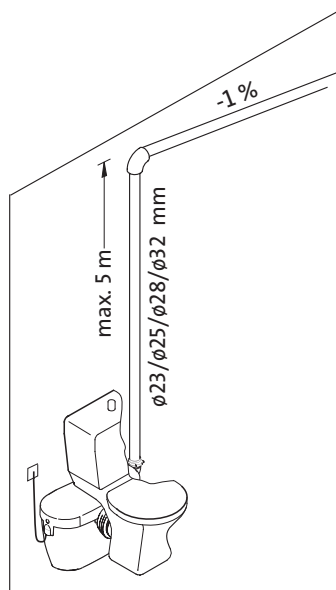

TM029285 2204

Pumped liquid

Sewage water from a toilet containing toilet paper and faeces.

Liquid temperature: Maximum 40°C.

Ordinary liquids for cleaning of the toilet.

pH value: 4 to 10.

No strong chemicals or solvents.

Features

- Unique design with smooth line and rounded edges - fits every modern bathroom environment
- Plug-and-go product - all you need in one package
- Low noise level
- Discharge pipe connection in the side ensures easy maintenance
- Flexible discharge pipe adapters for outer pipe diameters of Ø23, Ø25, Ø28 and Ø32 mm
- Thermal overload switch

Components

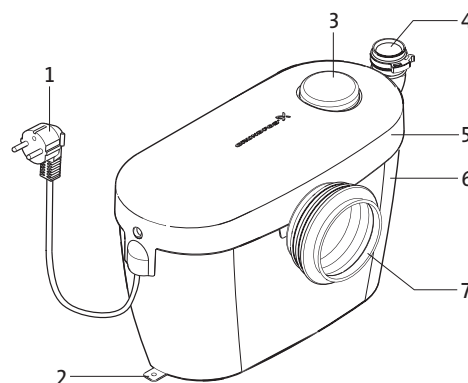

TM02 9288 2204

Pos.	Description
1	Connecting cable
2	Floor fittings
3	Vent valve
4	Discharge connection
5	Top cover
6	Tank
7	Toilet connection

Technical data

Mechanical data

Net weight:	5.4 kg
Flexible discharge elbow:	Ø23, Ø25, Ø28, Ø32 mm
Toilet connection:	Toilet with horizontal outlet according to EN 33 or EN 37. The toilet must use at least 6 litres per flush.
Start and stop levels:	Start: 63 mm above tank bottom Stop: 40 mm above tank bottom

Electrical data

Supply voltage:	1 x 220-240 V
Frequency:	50 Hz
Power consumption P1:	400 W
Rated current:	1.8 A
Power factor:	cos phi 0.8
Speed:	2850 min ⁻¹
Enclosure class:	IP 44
Insulation class:	F
Connecting cable:	1.2 m

Dimensions

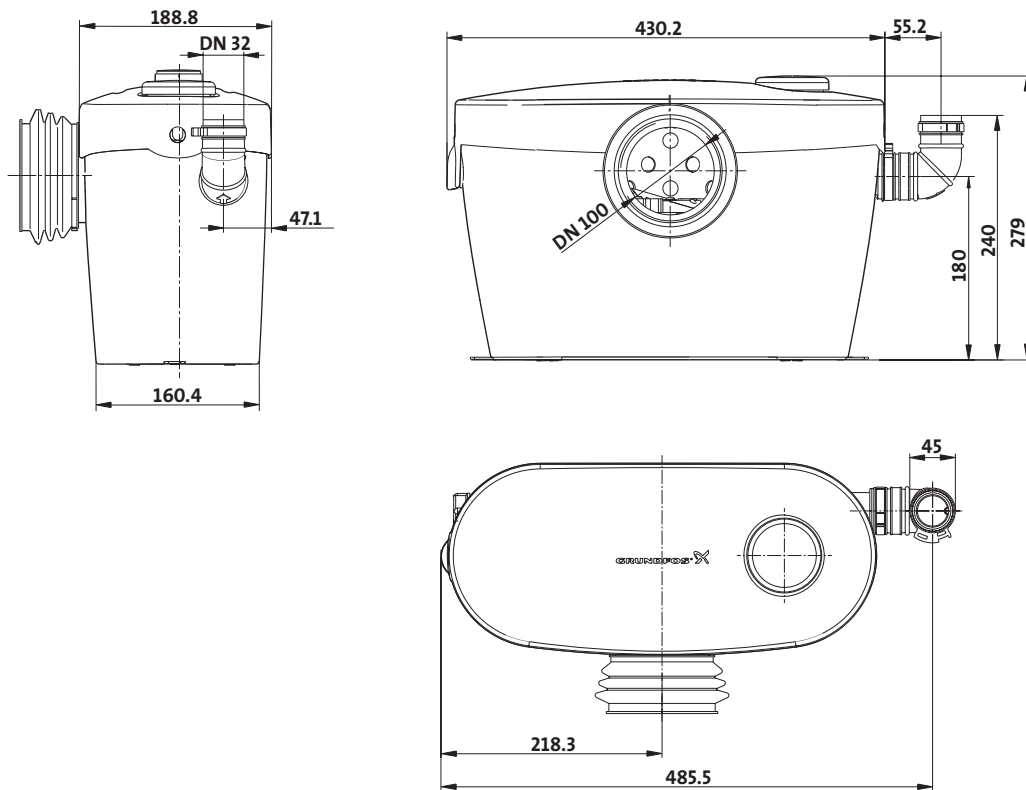

TM02 9157 2004

Discharge pipe

The following drawing shows the maximum lengths of vertical and horizontal discharge pipes.

Note: The first part of the discharge pipe must always be vertical.

All horizontal pipes must have a fall of 1:100 to the soil pipe.

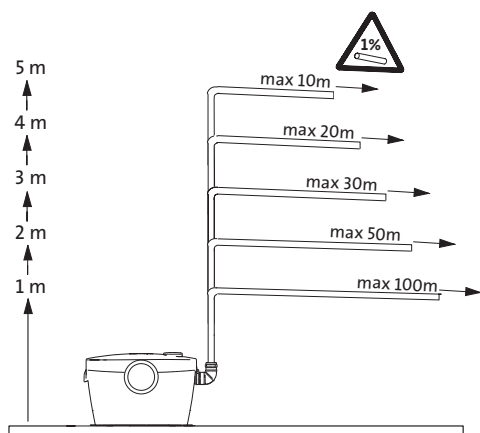

Sololift+ WC-1

Sololift+ WC-1 is a small, compact automatic lifting station with integrated cutter system. It is suitable for pumping of wastewater off places in private dwellings where wastewater cannot be led directly to the sewer by means of a natural downward slope.

Applications

Sololift+ WC-1 is typically used for:

- toilets and washbasins in basements below sewer level and
- toilets and washbasins installed in connection with the renovation or modernisation of existing buildings, where the location may be remote from the main soil pipe so that a natural slope cannot be established.

Sololift+ WC-1 is suitable for pumping wastewater from a washbasin as well as sewage water from a toilet containing toilet paper and faeces. The pumping of liquids containing other material may cause faults and limit the scope of our guarantee.

Example of application

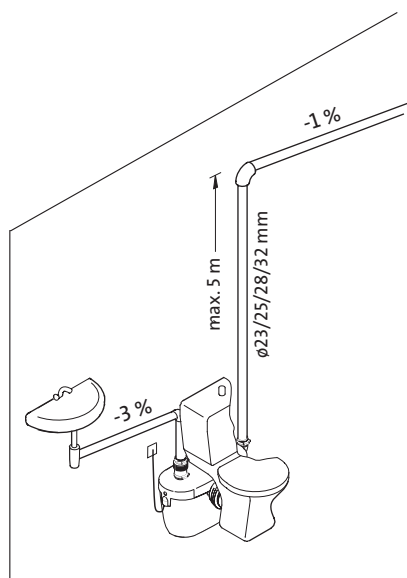

TM02 9476 2204

Pumped liquid

Wastewater from a washbasin and sewage water from a toilet containing toilet paper and faeces.

Liquid temperature: Maximum 40°C.

Ordinary liquids for cleaning of the units connected.

pH value: 4 to 10.

No strong chemicals or solvents.

Features

- Unique design with smooth line and rounded edges - fits every modern bathroom environment
- Plug-and-go product - all you need in one package
- Discharge pipe connection in the side ensures easy maintenance
- Flexible discharge pipe adapters for outer pipe diameters of $\varnothing 23$, $\varnothing 25$, $\varnothing 28$ and $\varnothing 32$ mm
- Cover without screws - easy service
- Thermal overload switch

Components

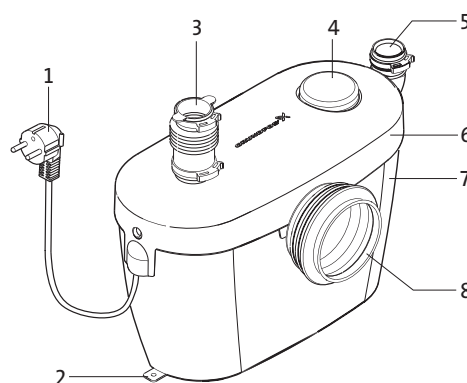

TM02 9289 2204

Pos.	Description
1	Connecting cable
2	Floor fittings
3	Connection in top cover
4	Vent valve
5	Discharge connection
6	Top cover
7	Tank
8	Toilet connection

Technical data

Mechanical data

Net weight:	5.4 kg
Flexible discharge elbow:	$\varnothing 23$, $\varnothing 25$, $\varnothing 28$, $\varnothing 32$ mm
Toilet connection:	Toilet with horizontal outlet according to EN 33 or EN 37. The toilet must use at least 6 litres per flush.
Dimensions of possible inlet:	1 x $\varnothing 40$ mm
Start and stop levels:	Start: 63 mm above tank bottom Stop: 40 mm above tank bottom

Electrical data

Supply voltage:	1 x 220-240 V
Frequency:	50 Hz
Power consumption P1:	400 W
Rated current:	1.8 A
Power factor:	cos phi 0.8
Speed:	2850 min ⁻¹
Enclosure class:	IP 44
Insulation class:	F
Connecting cable:	1.2 m

Dimensions

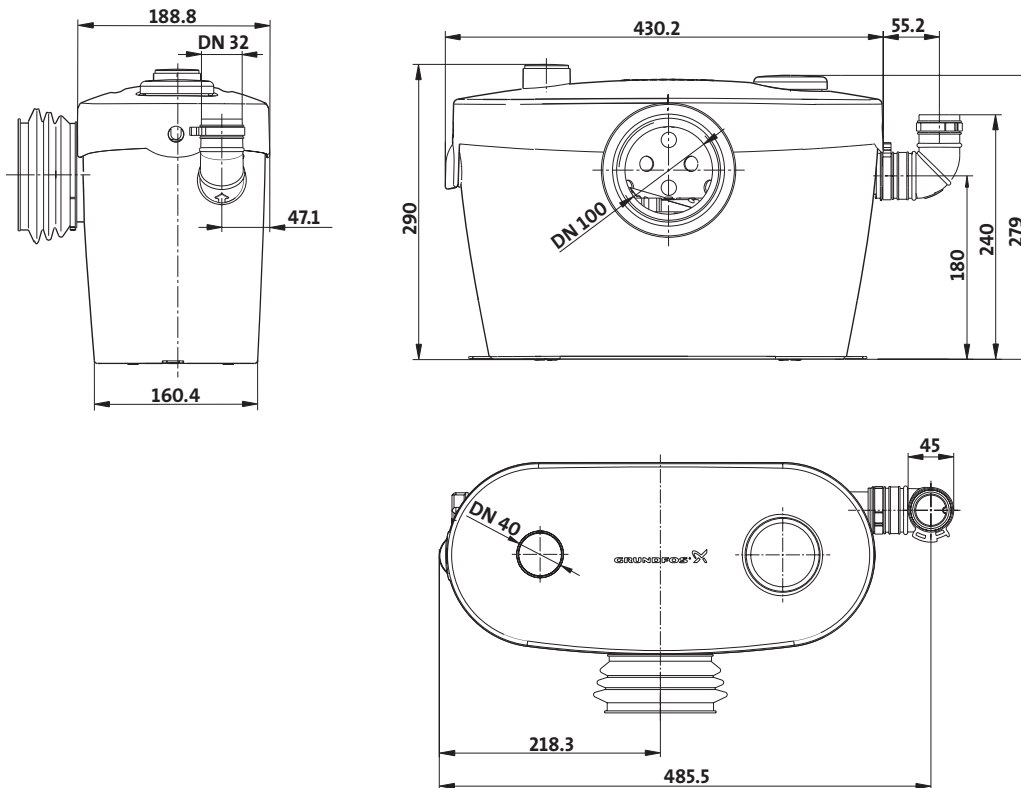

TM02 9168 2704

Discharge pipe

The following drawing shows the maximum lengths of vertical and horizontal discharge pipes.

Note: The first part of the discharge pipe must always be vertical.

All horizontal pipes must have a fall of 1:100 to the soil pipe.

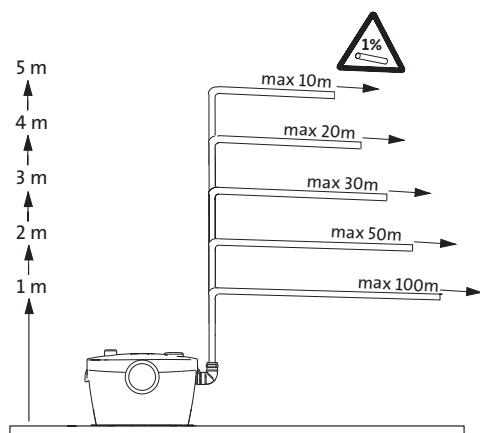

TM02 9492 2704

Sololift+ WC-3

Sololift+ WC-3 is a small, compact automatic lifting station with integrated cutter system. It is suitable for pumping of wastewater off places in private dwellings where wastewater cannot be led directly to the sewer by means of a natural downward slope.

Applications

Sololift+ WC-3 is typically used for:

- toilets, cabinet showers and washbasins in basements below sewer level and
- toilets, cabinet showers and washbasins installed in connection with the renovation or modernisation of existing buildings, where the location may be remote from the main soil pipe so that a natural slope cannot be established.

Sololift+ WC-3 is suitable for pumping wastewater from a cabinet shower and a washbasin as well as sewage water from a toilet containing toilet paper and faeces. The pumping of liquids containing other material may cause faults and limit the scope of our guarantee.

Example of application

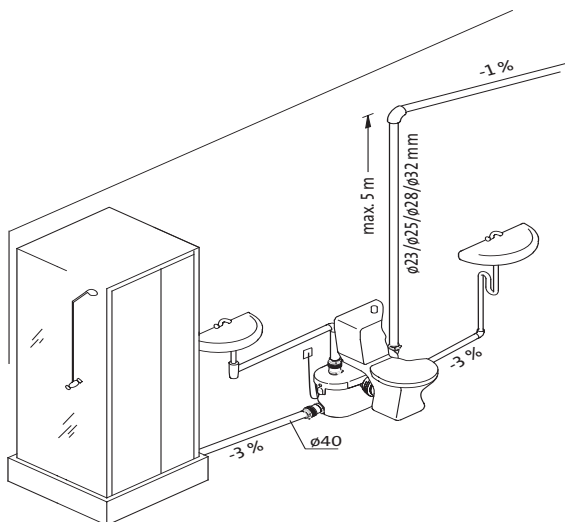

Pumped liquid

Wastewater from a shower and a washbasin as well as sewage water from a toilet containing toilet paper and faeces.

Liquid temperature: Maximum 40°C.

Ordinary liquids for cleaning of the units connected.

pH value: 4 to 10.

No strong chemicals or solvents.

Features

- Unique design with smooth line and rounded edges - fits every modern bathroom environment
- Three possible inlets in the top and side ensure easy connection of extra sanitary appliances
- Flexible discharge pipe adapters for outer pipe diameters of $\varnothing 23$, $\varnothing 25$, $\varnothing 28$ and $\varnothing 32$ mm
- Discharge pipe connection in the side ensures easy maintenance
- Thermal overload switch

Components

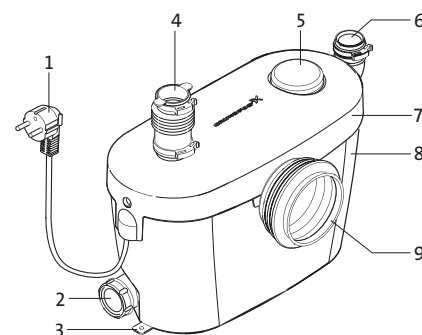

Pos.	Description
1	Connecting cable
2	Side connection
3	Floor fittings
4	Connection in top cover
5	Vent valve
6	Discharge connection
7	Top cover
8	Tank
9	Toilet connection

Technical data

Mechanical data

Net weight:	5.5 kg
Flexible discharge elbow:	$\varnothing 23$, $\varnothing 25$, $\varnothing 28$, $\varnothing 32$ mm
Toilet connection:	Toilet with horizontal outlet according to EN 33 or EN 37. The toilet must use at least 6 litres per flush.
Dimensions of possible inlets:	3 x $\varnothing 40$ mm
Start and stop levels:	Start: 63 mm above tank bottom Stop: 40 mm above tank bottom

Electrical data

Supply voltage:	1 x 220-240 V
Frequency:	50 Hz
Power consumption P1:	400 W
Rated current:	1.8 A
Power factor:	cos phi 0.8
Speed:	2850 min ⁻¹
Enclosure class:	IP 44
Insulation class:	F
Connecting cable:	1.2 m

Dimensions

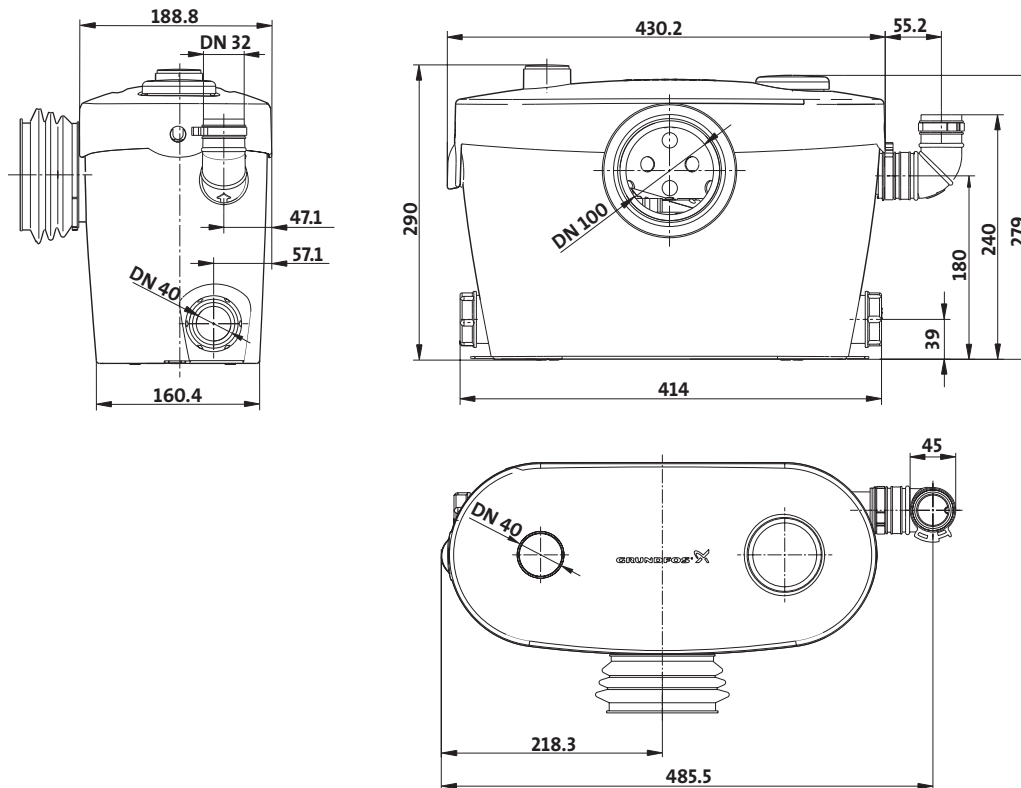

TM02 9159 2004

Discharge pipe

The following drawing shows the maximum lengths of vertical and horizontal discharge pipes.

Note: The first part of the discharge pipe must always be vertical.

All horizontal pipes must have a fall of 1:100 to the soil pipe.

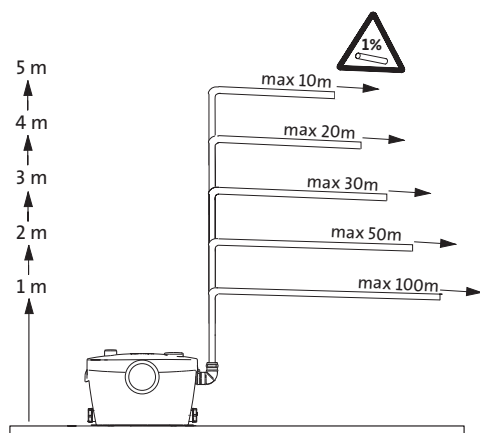

TM02 9409 2504

Sololift+ CWC-3

Sololift+ CWC-3 is a small, compact automatic lifting station suitable for pumping of wastewater off places in private dwellings where wastewater cannot be led directly to the sewer by means of a natural downward slope.

Applications

Sololift+ CWC-3 is typically used for:

- wall-hung toilets, cabinet showers and washbasins in basements below sewer level and
- wall-hung toilets, cabinet showers and washbasins installed in connection with the renovation or modernisation of existing buildings, where the location may be remote from the main soil pipe so that a natural slope cannot be established.

Sololift+ CWC-3 is suitable for installation in a hollow space behind a wall-hung toilet.

Sololift+ CWC-3 is suitable for pumping wastewater from a cabinet shower and a washbasin as well as sewage water from a toilet containing toilet paper and faeces. The pumping of liquids containing other material may cause faults and limit the scope of our guarantee.

Example of application

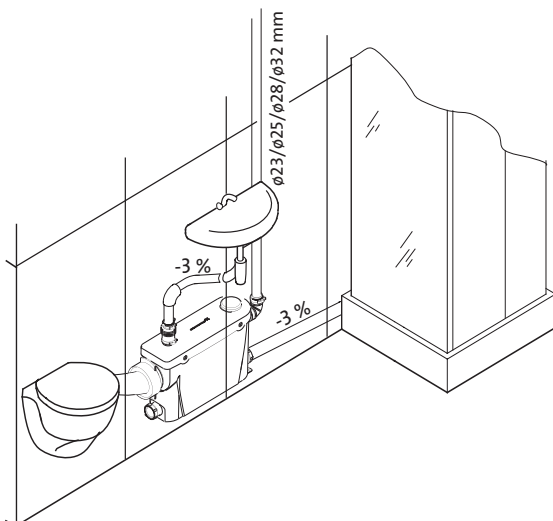

TM02 9379 2204

Pumped liquid

Wastewater from a shower and a washbasin as well as sewage water from a toilet containing toilet paper and faeces.

Liquid temperature: Maximum 40°C.

Ordinary liquids for cleaning of the units connected.

pH value: 4 to 10.

No strong chemicals or solvents.

Features

- Especially designed for wall-hung toilets
- Compact and slim for easy integration into the wall
- Three possible inlets in the top and side ensure easy connection of extra sanitary appliances
- Flexible discharge pipe adapters for outer pipe diameters of ø23, ø25, ø28 and ø32 mm
- Discharge pipe connection in the side ensures easy maintenance
- Thermal overload switch

Components

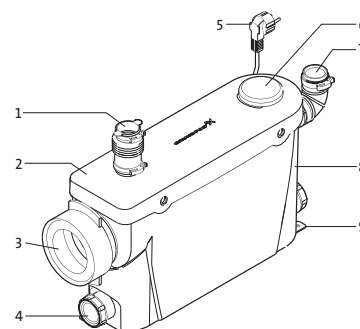

TM02 9378 2504

Pos.	Description
1	Connection in top cover
2	Top cover
3	Toilet connection
4	Side connections
5	Connecting cable
6	Vent valve
7	Discharge connection
8	Tank
9	Floor fittings

Technical data

Mechanical data

Net weight:	4.9 kg
Flexible discharge elbow:	ø23, ø25, ø28, ø32 mm
Toilet connection:	Toilet with horizontal outlet according to EN 33 or EN 37. The toilet must use at least 6 litres per flush.
Dimensions of possible inlets:	3 x ø40 mm
Start and stop levels:	Start: 85 mm above tank bottom Stop: 62 mm above tank bottom

Electrical data

Supply voltage:	1 x 220-240 V
Frequency:	50 Hz
Power consumption P1:	350 W
Rated current:	1.6 A
Power factor:	cos phi 0.8
Speed:	2850 min ⁻¹
Enclosure class:	IP 44
Insulation class:	F
Connecting cable:	1.2 m

Dimensions

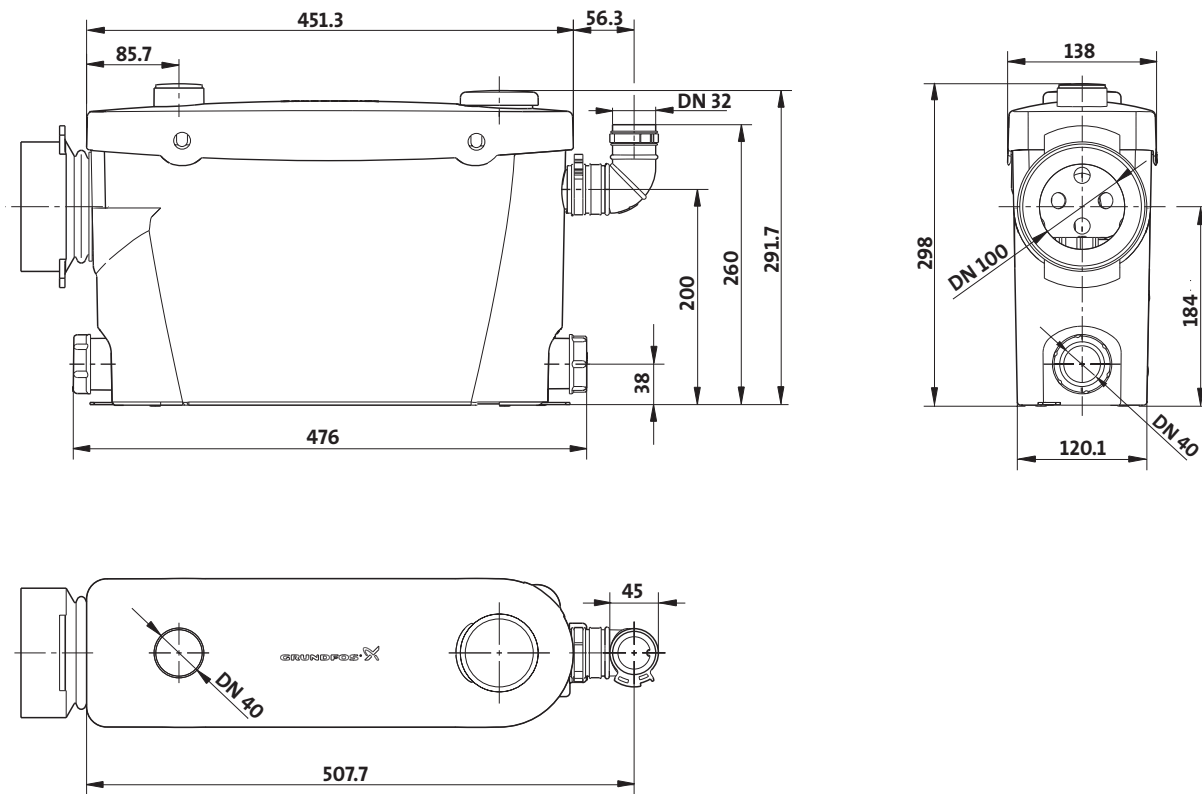

TM02 9160 2004

Discharge pipe

The following drawing shows the maximum lengths of vertical and horizontal discharge pipes.

Note: The first part of the discharge pipe must always be vertical.

All horizontal pipes must have a fall of 1:100 to the soil pipe.

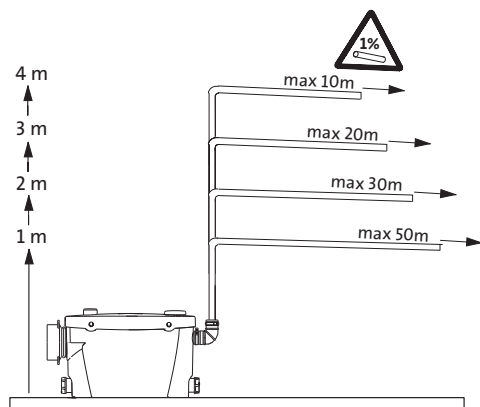

TM02 9411 2504

Sololift+ C-3

Sololift+ C-3 is a small, compact automatic lifting station suitable for pumping of wastewater off places in private dwellings where wastewater cannot be led directly to the sewer by means of a natural downward slope.

Applications

Sololift+ C-3 is typically used for:

- cabinet showers, washbasins, bath tubs, washing machines and dishwashers in basements below sewer level and
- cabinet showers, washbasins, bath tubs, washing machines or dishwashers installed in connection with the renovation or modernisation of existing buildings, where the location may be remote from the main soil pipe so that a natural slope cannot be established.

Sololift+ C-3 is suitable for installation under a washbasin or in a closet.

Example of application

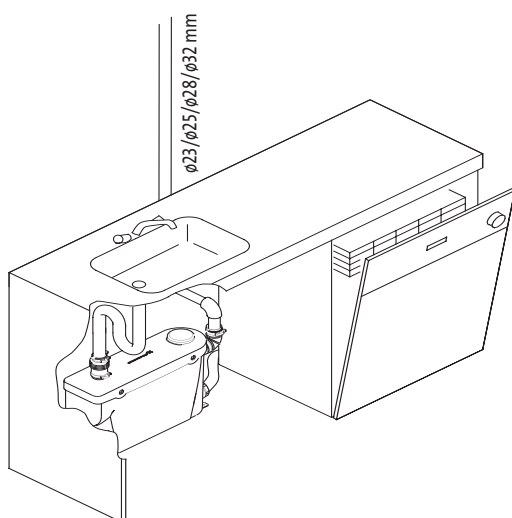

TM02 9412 2504

Pumped liquid

Wastewater from a washbasin, cabinet shower, bath tub, washing machine, dishwasher and similar units.

Liquid temperature: Maximum 70°C for two minutes.

Ordinary liquids for cleaning of the units connected.

pH value: 4 to 10.

No strong chemicals or solvents.

Features

- Especially designed for high liquid temperature - wastewater from washing machine or dishwasher
- Compact and slim for easy installation under a washbasin or in a closet
- Three possible inlets in the top and side ensure easy connection of extra appliances
- Flexible discharge pipe adapters for outer pipe diameters of ø23, ø25, ø28 and ø32 mm
- Discharge pipe connection in the side ensures easy maintenance
- Thermal overload switch

Components

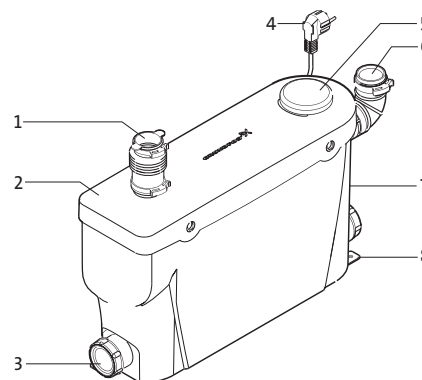

TM02 9383 2504

Pos.	Description
1	Connection in top cover
2	Top cover
3	Side connections
4	Connecting cable
5	Vent valve
6	Discharge connection
7	Tank
8	Floor fittings

Technical data

Mechanical data

Net weight:	4.7 kg
Flexible discharge elbow:	ø23, ø25, ø28, ø32 mm
Dimensions of possible inlets:	3 x ø40 mm
Start and stop levels:	Start: 86 mm above tank bottom Stop: 55 mm above tank bottom

Electrical data

Supply voltage:	1 x 220-240 V
Frequency:	50 Hz
Power consumption P1:	300 W
Rated current:	1.5 A
Power factor:	cos phi 0.8
Speed:	2850 min ⁻¹
Enclosure class:	IP 44
Insulation class:	F
Connecting cable:	1.2 m

Dimensions

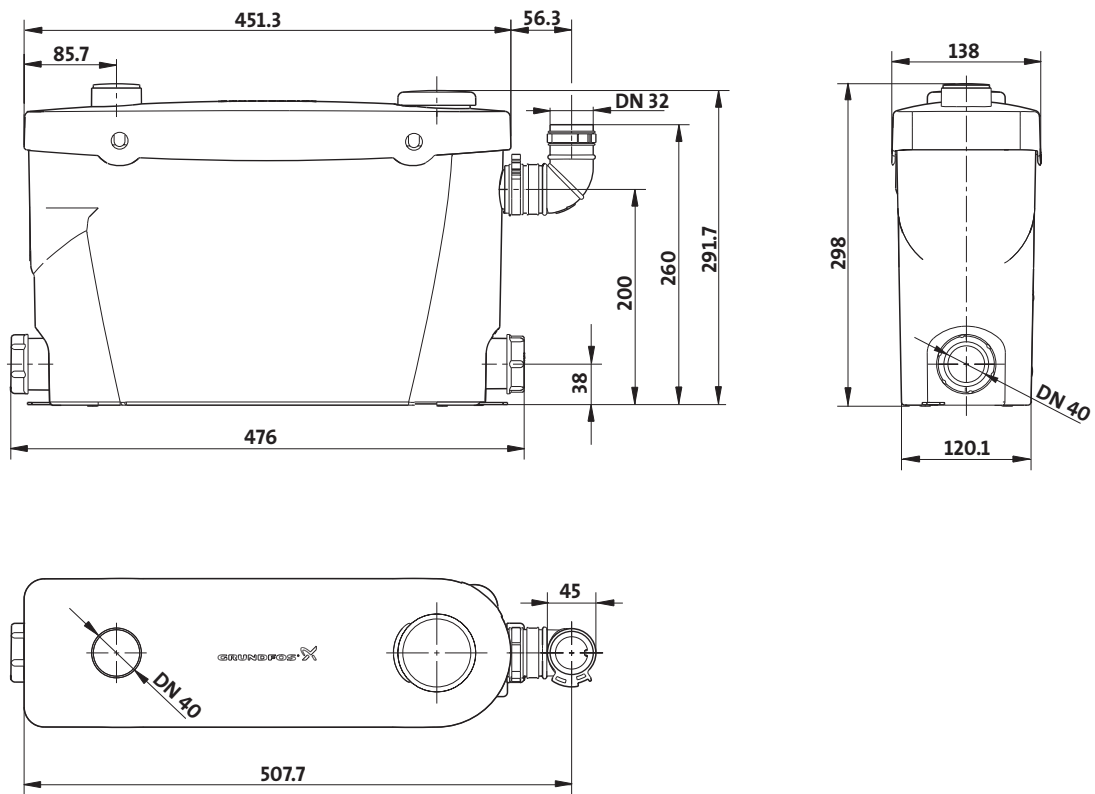

TM02 9161 2004

Discharge pipe

The following drawing shows the maximum lengths of vertical and horizontal discharge pipes.

Note: The first part of the discharge pipe must always be vertical.

All horizontal pipes must have a fall of 1:100 to the soil pipe.

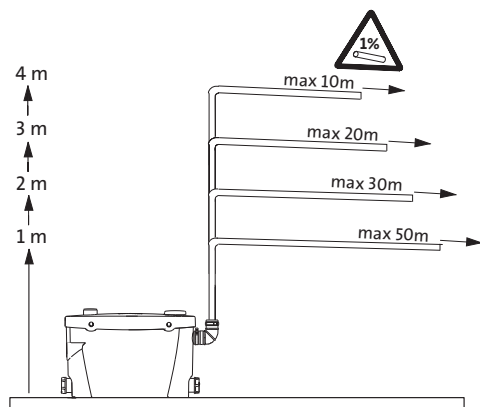

TM02 9490 2504

Sololift+ D-3

Sololift+ D-3 is a small, compact automatic lifting station suitable for pumping of wastewater off places in private dwellings where wastewater cannot be led directly to the sewer by means of a natural downward slope.

Applications

The Sololift+ D-3 is a compact unit especially designed for pumping of grey wastewater from washbasins or cabinet showers. It is possible to install Sololift+ D-3

- underneath the cabinet shower or
- next to the cabinet shower.

Example of application

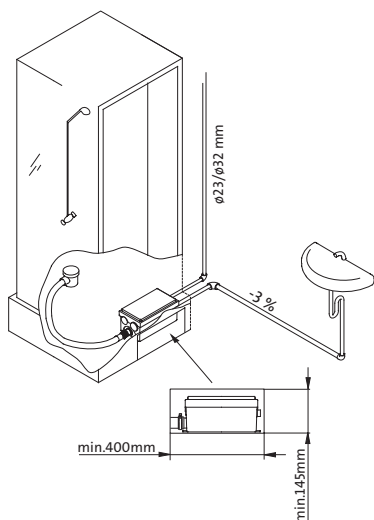

TM02 9293 2204

Pumped liquid

Wastewater from a washbasin and/or cabinet shower.

Liquid temperature: Maximum 40°C.

Ordinary liquids for cleaning of the units connected.

pH value: 4 to 10.

No strong chemicals or solvents.

Features

- Small and compact unit
- Designed for installation under a cabinet shower or for instance in a small closet
- Installs easily - all connections and fittings included
- Low activation level - pump starts when you turn on the water
- Thermal overload switch

Components

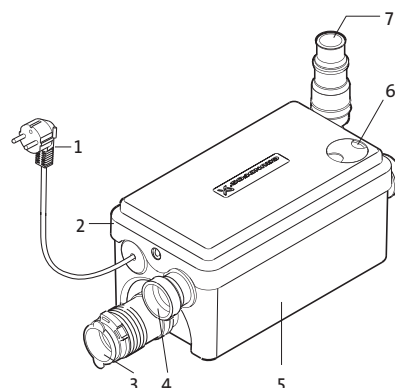

TM02 9291 2204

Pos.	Description
1	Connecting cable
2	Top cover
3	Connection to cabinet shower
4	Side connection
5	Tank
6	Vent valve
7	Discharge connection

Technical data

Mechanical data

Net weight:	3.5 kg
Flexible discharge elbow:	$\varnothing 23, \varnothing 32 \text{ mm}$
Dimensions of possible inlets:	2 x $\varnothing 40 \text{ mm}$, 1 x $\varnothing 32 \text{ mm}$
Start and stop levels:	Start: 55 mm above tank bottom Stop: 30 mm above tank bottom

Electrical data

Supply voltage:	1 x 220-240 V
Frequency:	50 Hz
Power consumption P1:	270 W
Rated current:	1.35 A
Power factor:	cos phi 0.8
Speed:	2850 min^{-1}
Enclosure class:	IP 44
Insulation class:	F
Connecting cable:	1.2 m

Dimensions

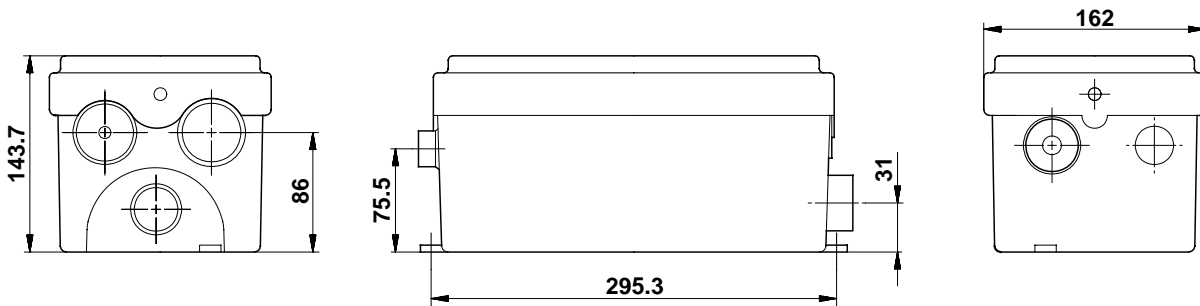

TM02 9290 2204

Discharge pipe

The following drawing shows the maximum lengths of vertical and horizontal discharge pipes.

Note: The first part of the discharge pipe must always be vertical.

All horizontal pipes must have a fall of 1:100 to the soil pipe.

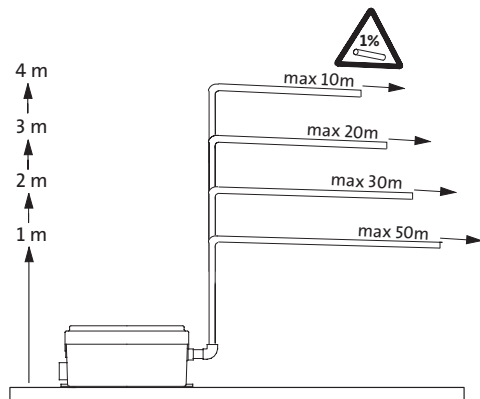

TM02 9312 2304

WebCAPS

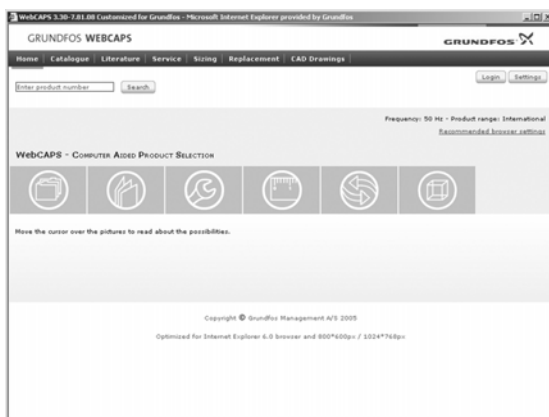

WebCAPS is a **Web**-based **Computer Aided Product Selection** program available on www.grundfos.com.

WebCAPS contains detailed information on more than 185,000 Grundfos products in more than 22 languages.

In WebCAPS, all information is divided into 6 sections:

- Catalogue
- Literature
- Service
- Sizing
- Replacement
- CAD drawings.

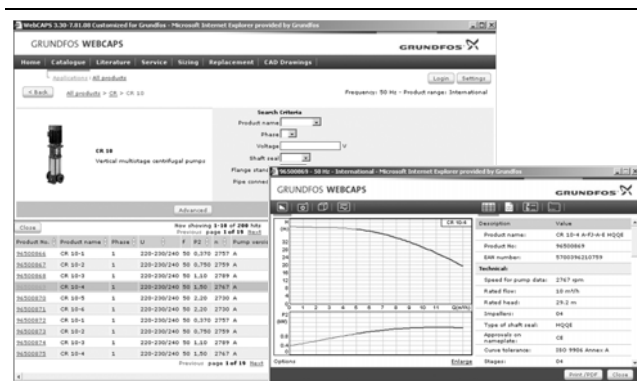

Catalogue

With a starting point in areas of applications and pump types, this section contains

- technical data
- curves (QH, Eta, P1, P2, etc) which can be adapted to the density and viscosity of the pumped liquid and show the number of pumps in operation
- product photos
- dimensional drawings
- wiring diagrams
- quotation texts, etc.

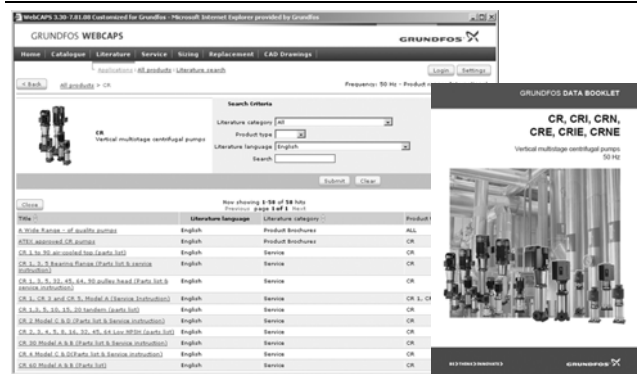

Literature

In this section you can access all the latest documents of a given pump, such as

- data booklets
- Installation and operating instructions
- service documentation, such as Service kit catalogue and Service kit instructions
- quick guides
- product brochures, etc.

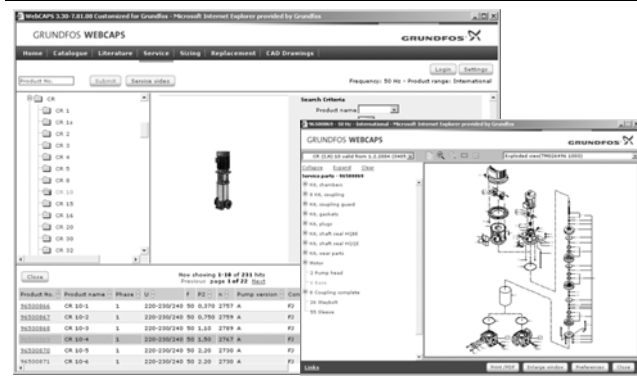

Service

This section contains an easy-to-use interactive service catalogue. Here you can find and identify service parts of both existing and cancelled Grundfos pumps.

Furthermore, this section contains service videos showing you how to replace service parts.



Sizing

With a starting point in different application areas and installation examples, this section gives easy step-by-step instructions in how to

- select the most suitable and efficient pump for your installation
- carry out advanced calculations based on energy consumption, payback periods, load profiles, lifecycle costs, etc.
- analyse your selected pump via the built-in lifecycle cost tool
- determine the flow velocity in wastewater applications, etc.



Replacement

In this section you find a guide to select and compare replacement data of an installed pump in order to replace the pump with a more efficient Grundfos pump.

The section contains replacement data of a wide range of pumps produced by other manufacturers than Grundfos.

Based on an easy step-by-step guide, you can compare Grundfos pumps with the one you have installed on your site. After having specified the installed pump, the guide suggests a number of Grundfos pumps which can improve both comfort and efficiency.



CAD drawings

In this section it is possible to download 2-dimensional (2D) and 3-dimensional (3D) CAD drawings of most Grundfos pumps.

The following formats are available in WebCAPS:

2-dimensional drawings

- .dxf, wireframe drawings
- .dwg, wireframe drawings.

3-dimensional drawings

- .dwg, wireframe drawings (without surfaces)
- .stp, solid drawings (with surfaces)
- .eprt, E-drawings.

WinCAPS



Fig. 1 WinCAPS CD-ROM

WinCAPS is a **Windows-based Computer Aided Product Selection** program containing detailed information on more than 185,000 Grundfos products in more than 22 languages.

The program contains the same features and functions as WebCAPS, but is an ideal solution if no Internet connection is available.

WinCAPS is available on CD-ROM and updated once a year.

96556256 0806	GB
Repl. 96556256 0805	

Subject to alterations.