

DMX

Dosing pumps

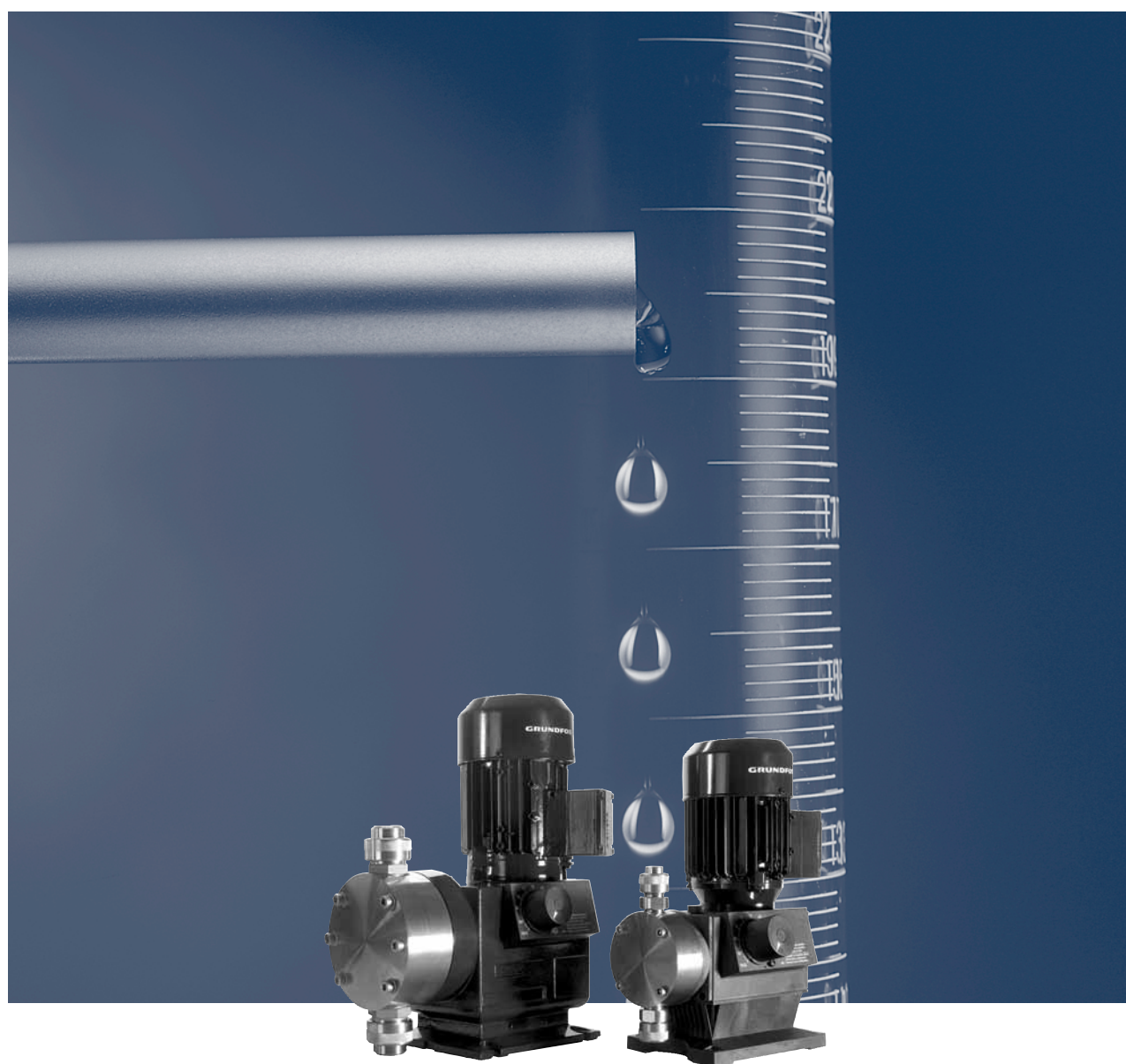

Contents

Features and benefits

DMX	3
-----	---

Performance range

DMX, 1.3 to 166 GPH	4
---------------------	---

Identification

Type key	5
----------	---

Functions

Functional overview	6
Capacity control	6
Functional description, DMX B	7
Functional description, DMX AR	7
DMX AR	8
Control panel	8
Connectors	8

Construction

General description	14
DMX model 221	14
DMX model 226	15

Technical data

Dimensions, DMX model 221	16
Dimensions, DMX model 226	17
Performance data, DMX model 221	18
Performance data, DMX model 226	19
Suction lift, DMX model 221	20
Suction lift, DMX model 226	21
Weights, DMX model 221	22
Weights, DMX model 226	22
Sound pressure	23
Accuracy	23
Permissible temperatures of dosing liquid	23

Pump selection

DMX selection (1.3 to 2 x 166 GPH)	24
------------------------------------	----

Pumped liquids

List of pumped liquids	26
------------------------	----

DMX

Reliable diaphragm dosing

from 1.3 to 2 x 166 GPH.



TM03 2134 3705

Fig. 1 DMX

DMX 221 and 226 - versatility through choice

The Grundfos DMX is a series of high-quality mechanically actuated diaphragm pumps suitable for many uses, such as drinking water treatment, wastewater treatment, and the pulp/paper and textile industries. This series is designed to be highly versatile, which is reflected in the wide flow range covered and the choice of dosing head sizes, materials, and accessories available. If in doubt, ask us – we will help you configure the DMX that is best for you.

Manual or remote reliable control

DMX B models feature manual stroke length adjustment for a 10:1 turndown ratio. For additional control the DMX AR features a micro-processor controller with:

- precise and automatic proportional feed
- manual stroke-frequency control
- 0(4)-20 mA or pulse control
- menu-driven display with user-friendly interface
- low-level and empty output
- remote on/off control.

Choose the materials – and size – that suit you

Both the DMX 221 and 226 liquid ends are available in PVC, PVDF, polypropylene, and stainless steel. For additional output and flexibility, the DMX 226 is available in a duplex version.

Accessories ensure perfect system integration

A wide range of accessories specially designed for the Grundfos DMX series help optimize performance. This makes commissioning fast and easy. Other accessories are also available to make sure that your Grundfos DMX fits your system exactly, such as:

- back-pressure valves for dosing systems with no or varying back pressure
- servomotor for remote stroke-length control via 4-20 mA input
- DMX AR dosing controller with output to indicate a loss
- DMX AR with leak detection
- DMX with integrated pressure relief valve in the pump head.

DMX, 1.3 to 166 GPH

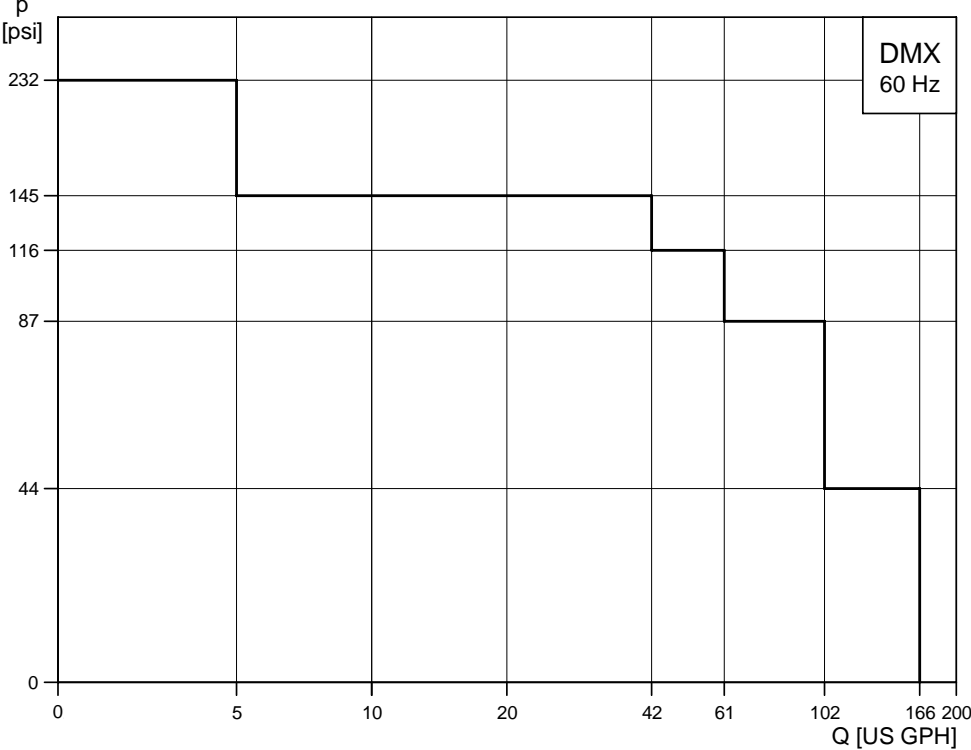

TN03 4776 2706

Fig. 2 Performance range, DMX, 1.3 to 166 GPH

Type key

Example:		DMX	115	-3	B	PVC	/V	/G	-X	-H	1	A7A7	B
Type range													
DMX													
Maximum flow [l/h]													
Maximum pressure [bar]													
Control variant													
B	Standard - manual control												
AR	Analog/pulse control (Etron Profi)												
AT0	Prepared for servomotor												
AT3	Servomotor, 1 x 230 V, 50/60 Hz supply, 4-20 mA control												
AT5	Servomotor, 1 x 115 V, 50/60 Hz supply, 4-20 mA control												
AT6	Servomotor, 1 x 230 V, 50/60 Hz supply, 4-20 mA control, EEx d II BT 4												
AT7	Servomotor, 1 x 115 V, 50/60 Hz supply, 4-20 mA control, EEx d II BT 4												
AT8	Servomotor, 1x230V 50/60Hz supply, 1K Ω potentiometer control												
AT9	Servomotor, 1x115V 50/60Hz supply, 1K Ω potentiometer control												
Dosing head variant													
PP	Polypropylene												
PV	PVDF (polyvinylidene fluoride)												
PVC	Polyvinyl chloride												
SS	Stainless steel, 316												
PV-R	PVDF + integrated relief valve												
PVC-R	PVC + integrated relief valve												
PP-L	PP + integrated diaphragm leakage detection												
PV-L	PVDF + integrated diaphragm leakage detection												
PVC-L	PVC + integrated diaphragm leakage detection												
SS-L	SS + integrated diaphragm leakage detection												
PV-RL	PVDF + integrated relief valve and diaphragm leakage detection												
PVC-RL	PVC + integrated relief valve and diaphragm leakage detection												
Gasket material													
E	EPDM (ethylene propylene diene monomer)												
V	FKM (fluorocarbon)												
T	PTFE (polytetrafluoroethylene, e.g. Teflon [®])												
Valve ball material													
C	Ceramic												
G	Glass												
T	PTFE (polytetrafluoroethylene, e.g. Teflon [®])												
SS	Stainless steel, 316												
Control panel position													
X	No control panel												
S	Side-mounted												
W	Wall-mounted												
Motor variant													
E0	PTC motor for frequency control												
E1	Motor type EEx de C T3, 3 x 400 V, 50 Hz (only DMX-B or DMX-AT)												
E2	Motor type EEx de C T4, 3 x 400 V, 50 Hz (only DMX-B or DMX-AT)												
Mains plug													
X	No plug												
F	EU (Schuko)												
B	USA, Canada												
I	Australia, New Zealand, Taiwan												
E	Switzerland												
Connection, suction/discharge													
4	Tube 6/9 mm												
6	Tube 9/12 mm												
B9	Tube 19/27 mm, PVC												
Q	Tube 19/27 mm and 25/34 mm												
S	Tube 3/8" / 1/2"												
A	Threaded Rp 1/4"												
A1	Threaded Rp 3/4"												
A2	Threaded Rp 1 1/4"												
V	Threaded NPT 1/4"												
A9	Threaded NPT 1/2", male												
A3	Threaded NPT 3/4"												
A7	Threaded NPT 3/4", male												
A4	Threaded NPT 1 1/4"												
A8	Threaded NPT 1 1/4", male												
K	Cementing d. 40 mm												
B1	Tube 6/12 mm/cementing d. 12 mm												
B2	Tube 13/20 mm/cementing d. 25 mm												
B3	Welding d. 16 mm												
B4	Welding d. 25 mm												
B5	Welding d. 40 mm												
Valve type													
1	Standard												
2	Spring-loaded 1.45 psi inlet opening pressure 1.45 psi discharge opening pressure												
3	Spring-loaded, 0.7 psi inlet opening pressure 11.6 psi discharge opening pressure												
4	Spring-loaded, discharge side only												
5	Valve for abrasive liquids												
Supply voltage													
0	Without motor, IEC flange												
G	1 x 230 V, 50/60 Hz												
H	1 x 120 V, 50/60 Hz												
E	230/400 V, 50/60 Hz or 440/480 V, 60 Hz												
	Without motor, NEMA flange (US)												
F	Nema 42C for DMX 221 Nema 56C for DMX 226												
J	220-240 V / 380-420 V, 50/60Hz												
5	3 x 230/460 V, 60 Hz												

Functional overview

	DMX B	DMX AR
Capacity control		
Stroke-frequency control		•
Stroke-length adjustments	•	•
Control panel		
Red light for stopped pump and error signals		•
Green light when pump is running		•
Control-panel lock		•
[Start/Stop] button		•
Front-mounted interface		•
Wall-mounted interface		•
Operating modes		
Manual control	•	•
Pulse control		•
Analog 0/4-20 mA control		•
Pulse-based batch control		•
Functions/options		
Alarm outputs		•
Dosing controller output		•
Leak detection (optional diaphragm breakage indication)	•	•
Dual-level control (requires level controller, available on select sizes)		•
Pulse memory (saves up to 65,000 pulses)		•
Operating-hours counter		•
Remote on/off		•
0/4-20 mA output		•
Available in duplex versions (Check sizing chart for availability)	•	•



Fig. 3 DMX B

TM03 2134 3705



Fig. 4 DMX AR

TM03 6124 4306

Capacity control

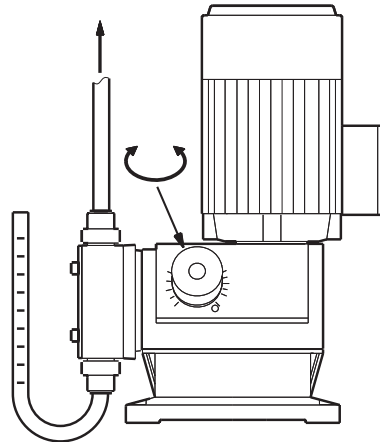

Fig. 5 The capacity is controlled by adjusting the stroke length

TM03 2023 3505

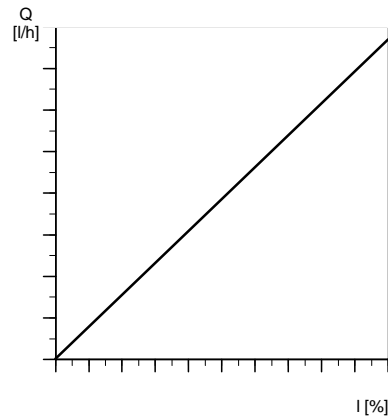

Fig. 6 Relation between stroke length and capacity

TM03 2097 3705

Functional description, DMX B

On the DMX B, the capacity is controlled by means of the stroke-length adjusting knob. The stroke frequency remains constant.

As shown in fig. 8, the stroke frequency is constant while only the stroke length is adjusted.



Fig. 7 DMX B

TM03 2134 3705

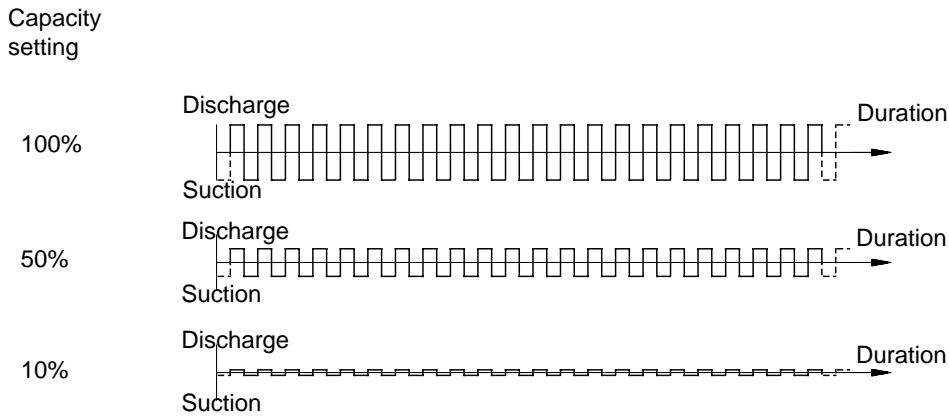

Fig. 8 Relation between stroke-length adjustment and capacity on the DMX B

TM03 2074 3505

Functional description, DMX AR

On the DMX AR, the capacity is set both by setting the stroke length on the gearbox knob and the stroke frequency on the control unit. The control unit controls the stroke frequency by starting and stopping the motor according to the set stroke frequency. Figure 10 shows two examples:

1. The pump is running at 100% capacity at maximum stroke length and stroke frequency.
2. The pump is running at 25% capacity at 50% stroke length and 50% stroke frequency.



Fig. 9 DMX AR

TM03 6124 4306

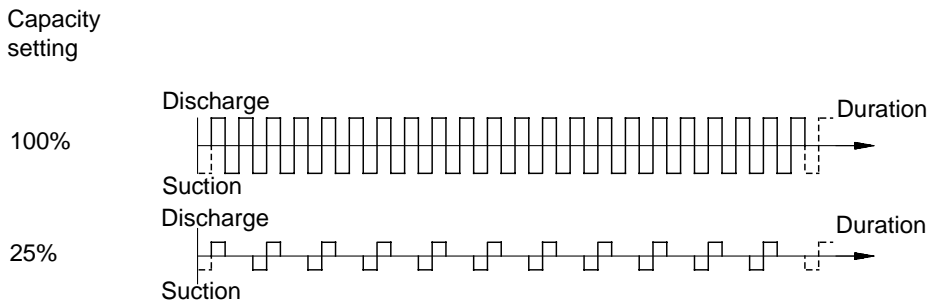

Fig. 10 Capacity setting on the DMX AR

TM01 8964 0900

DMX AR

Control panel

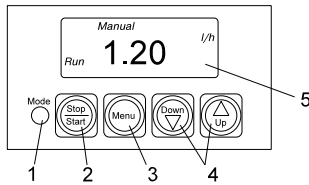

Fig. 11 Control panel

Legend

Pos.	Component
1	Mode (light-emitting diode): <ul style="list-style-type: none"> • Red light indicates that the pump has stopped. • Green light indicates that the pump has started; the light is briefly off during a suction stroke. • Yellow light indicates that the pump is switched off remotely. • Red light is flashing in case of an error signal. • Light is off when the pump is in menu mode.
2	Start/Stop (button): <ul style="list-style-type: none"> • For starting and stopping the pump.
3	Menu (button): <ul style="list-style-type: none"> • For switching between operating modes.
4	Up/Down (buttons): <ul style="list-style-type: none"> • For changing the values in the display.
5	LCD display

Start/stop of pump

Start and stop the pump by means of the [Start/Stop] button. When the pump is stopped, the display shows "stop". If the pump is stopped via an external start/stop signal, the indicator light is permanently yellow.

Operating modes

To select the operating mode, press the [Menu] button. The display indicates the operating mode. To change the mode, use the [Up/Down] buttons, see fig. 11, pos. 4.

Manual control

The pump is dosing constantly according to the set stroke length. Thanks to its control panel, DMX AR also offers setting of the stroke frequency.

Pulse control

Pulse control applies to DMX AR.

The pump is dosing according to an external pulse signal such as a water meter.

TM03 4455 2106

Connectors

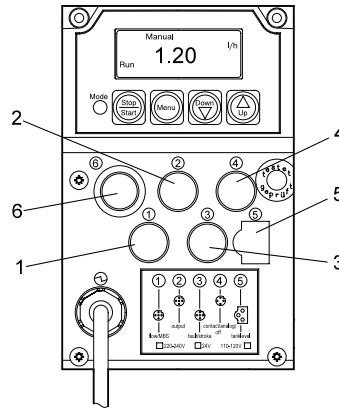

Fig. 12 Connectors

Legend

Socket	Description
1	Leakage detection
2	Current output (indicates the current dosing flow)
3	Output for stroke/pulse signal or empty-tank pre-alert signal and error signal
4	Remote on/off Contact input Current input
5	Empty-tank signal Empty-tank pre-alert and empty-tank signal

The number of pump strokes per pulse (multiplication) can be set between 1:1 and 1:999 and the number of pulses per stroke (division) between 999:1 and 1:1.

Tank-level control

The tank-level control function applies to DMX AR.

The pump can be fitted with a level-control unit for monitoring the chemical level in the tank. The pump can react to two level signals. The following table shows the pump reactions to the sensor signals.

Level sensors	Pump reaction
Pre-empty sensor activated	<ul style="list-style-type: none"> • Red indicator light is on. • Empty signature in display is flashing. • Pump running. • Alarm relay activated.
Empty sensor activated	<ul style="list-style-type: none"> • Red indicator light is on. • Empty signature in display is on. • Pump stopped. • Alarm relay activated.

TM03 7226 4606

Maximum permissible stroke frequency

The maximum permissible stroke-frequency function applies to DMX-AR.

The maximum stroke frequency of the pump can be limited, for instance to adapt pump operation to an analog 0/4-20 mA signal without reducing the stroke length.

Alarms

The pump allows to control the metering process. An alarm is indicated visually in the display and forwarded by the alarm relay.

Tank pre-empty alarm signalling

The indicator light flashes, and the pre-empty relay is activated.

Empty-level main alarm

The indicator light is on, and the alarm relay is activated. The pump stops.

Alarm relay

The alarm relay can be set to NO or NC.

Functions of indicator lights and alarm output

Condition	Indicator light
Pump running	Light flashes green
Set to stop	Light is permanently red
Pump fault	Light flashes red
Supply failure	Light is off
Pump running, low chemical level*	Light flashes red/green
Empty tank *	Light is permanently red
Analog signal < 2 mA	Light flashes red

* Requires connection to level sensors.

It is possible to programme one relay to pre-empty and another to empty signal.

Diaphragm Breakage Signal and dosing controller

Socket 1

Socket 1 can be used for the Diaphragm Breakage Signal (MBS) and/or the dosing controller (DC). The Diaphragm Breakage Signal and the dosing controller are delivered pre-assembled with an M12 plug for socket 1.

When simultaneously using the diaphragm breakage indication and the dosing controller, both cables must be connected with one plug.

Pin	Assignment	Wire colours		Dosing controller
		Diaphragm Breakage Signal		
		Cable, 0.8 metre	Cable, 3 metres (without plug)	
1	+12V			Brown
2	MBS/GND	White	White	
3	MBS supply	Blue	Blue	
4	Dosing controller output			Blue
5	MBS output	Green/yellow	Green	

Current output and remote on/off

Caution: The current output is not designed for controlling secondary pumps in master/slave operation.

Socket 2

Socket 2 can be used for the remote switching input and current output.

The current output indicates the current dosing flow and can be weighted independently of the selected operating mode.

Pin	Assignment	Cable	Used for	
		Wire colour	+/- current output	remote switching
1	+5 V	Brown	+	
2	Remote switching input	White		X
3	GND	Blue		X
4	Current output	Black	-	

Stroke signal, pre-empty signal, and error signal

Note: Use the stroke signal to control secondary pumps.

Socket 3

Socket 3 can be used for electrically isolated output for stroke signal or pre-empty signal and error signal.

Pin	Assignment	Cable	Used for	
		Wire colour	stroke signal/ pre-empty signal	remote switching
1	Error signal contact	Brown		X
2	Stroke signal or pre-empty signal contact	White	X	
3	Stroke signal or pre-empty signal contact	Blue	X	
4	Error signal contact	Black		X

Remote on/off, contact input and current input

Caution: The current input is not designed for controlling a preceding pump in master/slave operation. Instead, use the contact input that controls socket 3.

Socket 4

Socket 4 can be used for the remote switching input and contact input or current input. In the event of the simultaneous connection of the remote switching and contact input, wire 1 is assigned twice.

Caution: For the connection of one cable, use a plug adapter with simple cable entry; for the connection of two cables, use a plug adapter with double cable entry. Otherwise, the protection will be lost!

Pin	Assignment	Cable		Used for	
		Wire colour	remote switching input	contact input	+/- current output
1	GND	Brown	x	x	-
2	Current input	White			+
3	Remote switching	Blue	x		
4	Current output	Black		x	

Empty signal, pre-empty and empty signals

Socket 5

Socket 5 can be used for the empty signal or pre-empty and empty signal inputs. The suction lines with empty signal or pre-empty and empty signals are delivered pre-assembled with a plug for socket 5.

Pin	Assignment	Used for	
		empty signal	pre-empty signal
1	Empty signal	x	
2	GND	x	x
3	Pre-empty signal		x

Menu levels

Menu levels used in the electronics

- First function level: This level is used for selecting and setting the pump operating modes (manual, contact and analog) and starting.
- Second function level: This level is used for setting and viewing additional functions and setting the access code to protect the pump against unintentional adjustment.
- Service level: This level is used for setting the inputs and outputs, modifying the version of the Etron Profi Electronics. It is possible to revert to the default settings.

Saving user settings

The pump settings are automatically saved approximately every 10 minutes. The settings remain after the power supply has been switched off.

General functions of the electronics

Deaeration and suction

If the [Start/Stop] button is pressed for more than one second, the pump switches to continuous operation. The pump remains in continuous operation as long as the button is pressed (for example for suction or deaeration).

This occurs regardless of the selected operating mode.

Locking 'run'

The pump can be locked to avoid manual stopping.

When activating the locking run function (service level), the pump starts running with the present settings and cannot be stopped by means of the [Start/Stop] button.

It is still possible to acknowledge error messages using the [Start/Stop] button.

Diaphragm Breakage Signal

As an option, the pump can be equipped with a sensor for Diaphragm Breakage Signal (MBS).

The electronics automatically detects whether a sensor is connected. The following appears in the display:

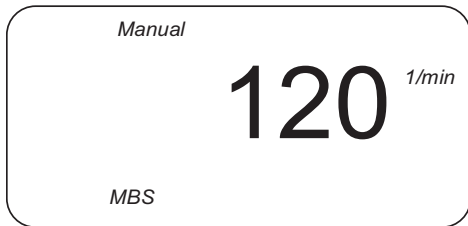

TM03 6021 4206

Fig. 13 Automatic detection of MBS sensor

When the sensor detects a diaphragm breakage, the following takes place:

- The pump is switched off.
- The error signal relay switches on.
- The LED flashes red.
- "MBS" and "ERROR" flash in the display.

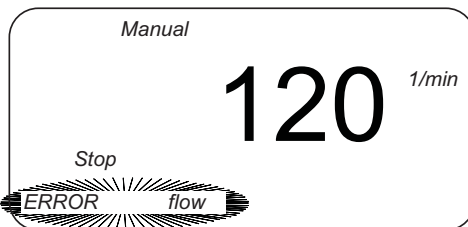

TM03 6023 4206

Fig. 14 Diaphragm breakage detected

Hall sensor and motor monitoring

If the pump has a queue of strokes to process, the Hall sensor checks whether the drive is turning. If the drive motor is blocked, for example due to excess counter-pressure in the dosing system, the integrated motor monitoring function detects and indicates the fault.

- The error signal relay switches on.
- "1/min", "bar" and "ERROR" flash in the display.
- The motor is not switched off.

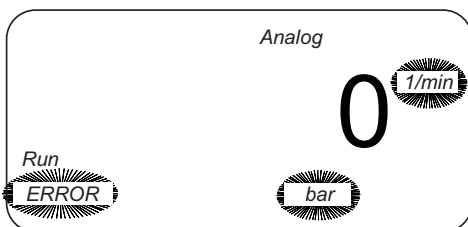

TM03 6027 4206

Fig. 15 Hall sensor and motor monitoring

Remote switching

The pump can be switched off remotely, for example from a control room.

- If the pump is switched off remotely, it does not respond to any input signals or to operator input. Exception: The pump can still be stopped and de-aerated manually.
- "Stop" lights up in the display.
- The yellow LED lights up.
- When switched on remotely, the pump returns to the state it was in before it was switched off. If, for example, the pump was previously in the "Stop" mode, it returns to this mode once it is switched on.

Dosing controller

A dosing controller can be connected to the pump as an option.

The dosing controller monitors the dosing process and emits a pulse for each dosing stroke.

- During start-up or after 5 seconds of downtime, the electronics automatically detects whether a dosing controller is connected. The following appears in the display:

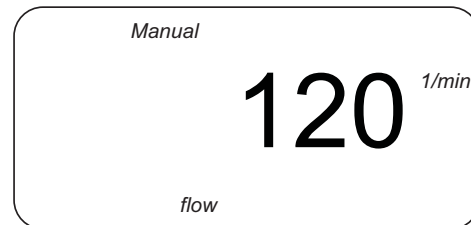

TM03 6022 4206

Fig. 16 Automatic detection of dosing controller

Signal outputs

Current signal output

The current output is linear between 4 (0) mA at stroke frequency = 0 and 20 mA at maximum stroke frequency of the pump. The current output cannot be weighted.

Error signal

The error signal is used for returning various error states to the control room.

Stroke signal and pre-empty signal

Depending on the relay setting, the contact output receives a signal in either of these cases:

- on each complete stroke of the pump
- on a pre-empty signal input.

Manual control

Dosing with manual on/off and manually adjustable dosing flow

In this operating mode, the operator enters all the settings on the pump.

Use the [Start/Stop] button to start or stop the pump.

Use the [Up/Down] buttons to increase or decrease the stroke frequency.

This can be done when the pump is stopped or when it is running.

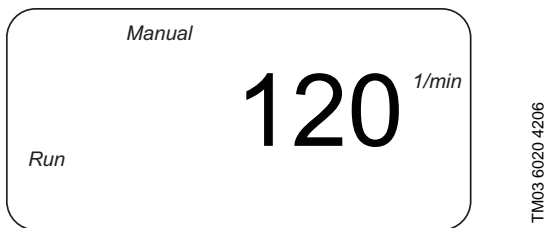

Fig. 17 Display in manual control mode

The maximum stroke frequency displayed is automatically set according to the mains frequency and the gear ratio.

Memory function and excess contact signals

Contact signals that cannot be processed immediately, can be stored and subsequently made available to the pump for processing. A maximum of 65,000 contact signals can be stored.

- Without memory: If the pump is running when a contact signal is received, the signal is ignored. The pump executes the current dosing, then it is again ready to receive new contact signals, i.e. it rejects excess contacts.
- With memory: If the pump is running when a contact signal is received, the signal is stored in the memory. First, the pump executes the current dosing, then it processes the contact signals from the memory.

The following actions reset the memory:

- switching off the mains voltage
- switching operating mode.

The following actions do **not** reset the memory:

- remote on/off
- pressing the [Start/Stop] button
- continuous operation.

Current signal control 0-20 mA or 4-20 mA

For controlling the dosing pump via a 0-20 mA (or 4-20 mA) external current signal

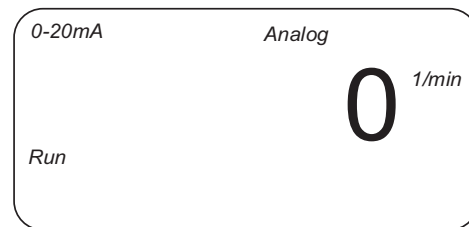

Fig. 18 0-20 mA

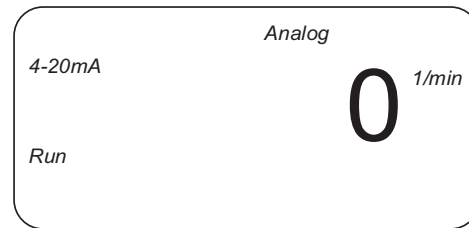

Fig. 19 4-20 mA

The stroke frequency is proportional to a 0-20 mA (4-20 mA) current input signal.

- Above 19.8 mA, the pump runs in continuous operation at maximum stroke frequency.
- Below 0.2 (4.2) mA, the pump switches off.
- Within this range, only integer stroke frequencies can be assigned.

4-20 mA current signal control

If the current input signal falls below 2 mA, the error relay is switched, as an error has probably occurred at the signal source or on the cable.

- The error signal relay switches on, the LED flashes red.
- "4-20 mA" and "ERROR" flash in the display

See fig. 20.

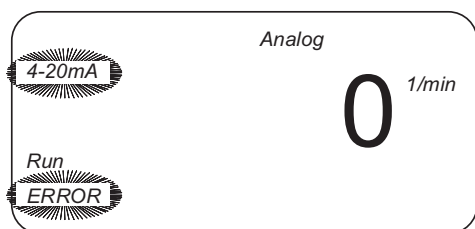

TM03 6026 4206

Fig. 20 4-20 mA, alarm limit

Dosing controller

If installed, the dosing controller can be switched on and off.

Memory function

The memory function is used for storing excess contact inputs for later processing.

Current input - weighting

Current signal control without weighting (default)

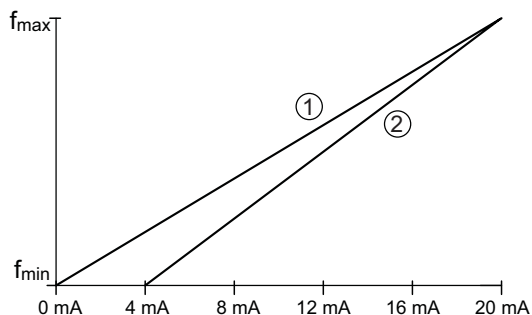

TM03 6123 4306

Fig. 21 Current input and current output without weighting

The assignment between the current signal and the stroke frequency is linear by default between 0 and the maximum stroke frequency (depending on the pump type) for a current input signal of 0 mA-20 mA (curve 1) or 4 mA-20 mA (curve 2). The current output corresponds to curve 1 for a current signal control of 0-20 mA and curve 2 for a current signal control of 4-20 mA and manual mode.

Current signal control with weighting

You can modify the pump response by setting a specific assignment between the current input and the stroke frequency.

In the second function level, first set the current value and then the stroke frequency in the menu items for current weighting for a reference point.

The maximum stroke frequency of the pump must not be exceeded!

Creating a master/slave application

You can connect several secondary pumps and control the secondary pumps (slaves) via the first pump (master).

General description

The Grundfos DMX pumps are mechanical diaphragm dosing pumps. The strokes are generated by an eccentric which moves the diaphragm by means of a spring-loaded plunger. The discharge stroke is activated by the eccentric and the suction stroke by the spring return.

The DMX pumps are designed for capacities between 1.3 and 2 x 166 GPH and a maximum pressure up to 232 psi. The DMX pumps are fitted with a separation chamber. In the event of a diaphragm failure, the separation chamber prevents the pumped liquid from flooding the pump unit or other system components.

DMX model 221

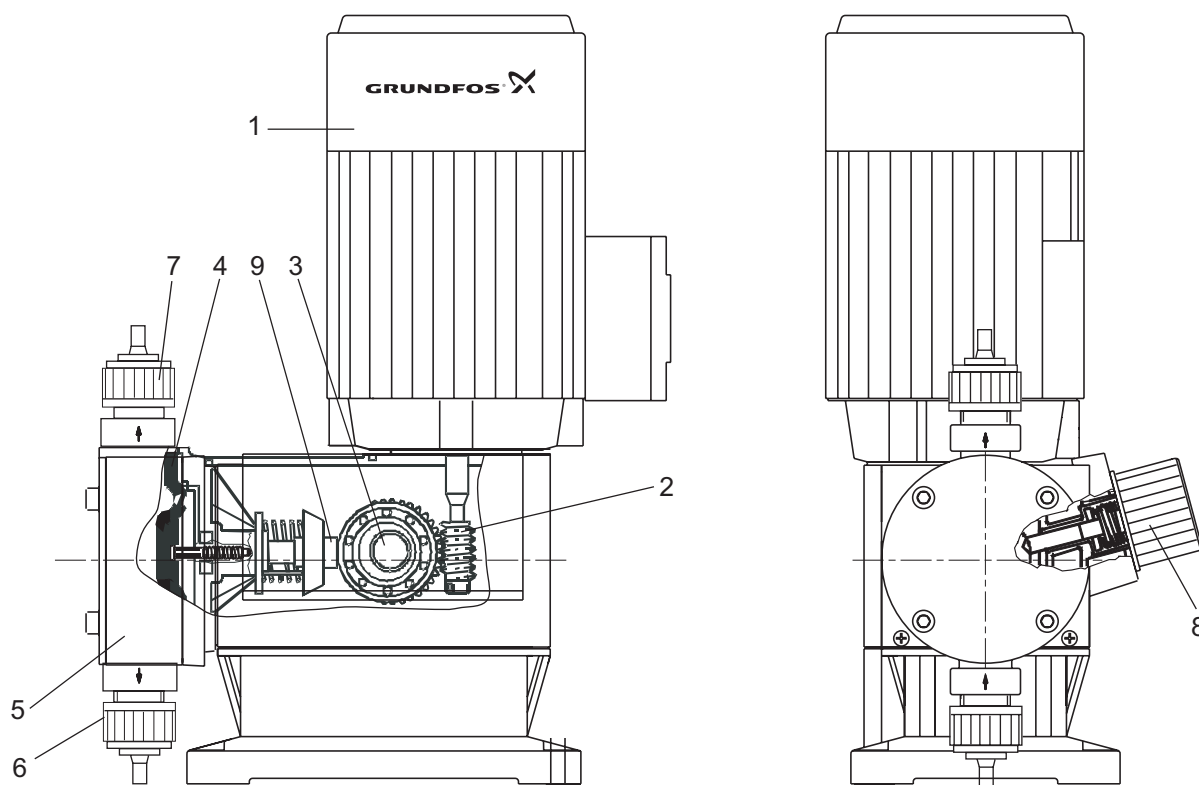

Fig. 22 Sectional drawing, DMX model 221

Functional principle

- Reciprocating displacement pump with electric motor and mechanical diaphragm control.
- The rotation of the motor is transformed into the reciprocating movement of the dosing diaphragm by the operation of the eccentric and tappet.
- Adjustment of the dosing flow is possible by adjusting the stroke length.

Legend:

Pos.	Component
1	Motor
2	Gears
3	Eccentric
4	Dosing diaphragm
5	Pump head
6	Suction valve
7	Discharge valve
8	Stroke-length adjusting knob
9	Tappet

TM03 2182 3805

DMX model 226

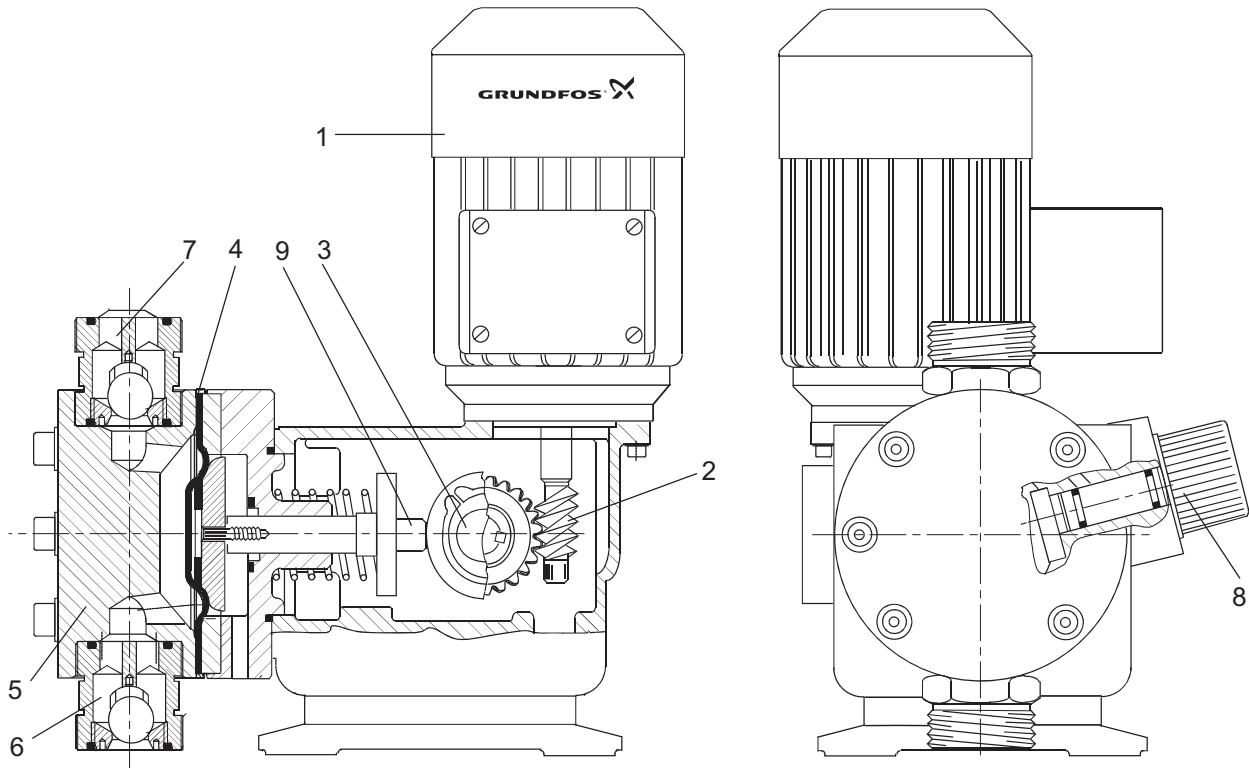

TM03 1869-3805

Fig. 23 Sectional drawing, DMX model 226

Functional principle

- Reciprocating displacement pump with electric motor and mechanical diaphragm control.
- The rotation of the motor is transformed into the reciprocating movement of the dosing diaphragm by the operation of the eccentric and tappet.
- Adjustment of the dosing flow is possible by adjusting the stroke length.

Legend:

Pos.	Component
1	Motor
2	Gears
3	Eccentric
4	Dosing diaphragm
5	Pump head
6	Suction valve
7	Discharge valve
8	Stroke-length adjusting knob
9	Tappet

Dimensions, DMX model 221

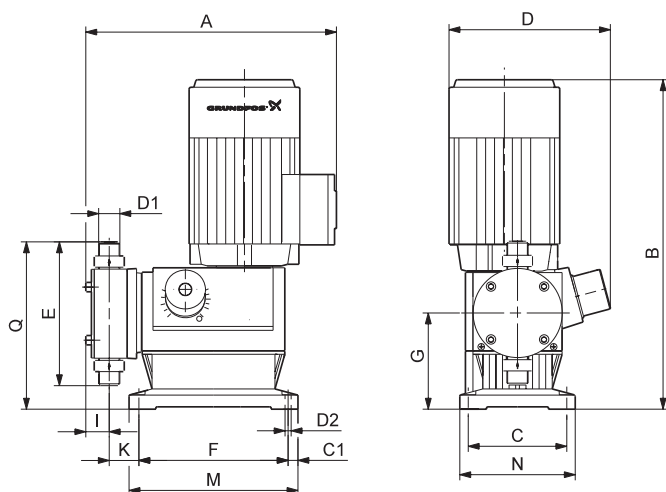

TM03 1731 3605

Fig. 24 Dimensions, DMX model 221

Dimensions in inches (mm)

Pump	Model	A	B	C	C1	D	D1	D2	E	F	G	I	K	M	N	Q
DMX 4-10	221	10.83 (275)	12.56 (319)	4.13 (105)	0.41 (10.5)	6.89 (175)	R 5/8	0.26 (6.5)	6.02 (153)	6.26 (159)	4.04 (102.5)	0.98 (25)	1.26 (32)	7.09 (180)	4.84 (123)	7.05 (179)
DMX 7-10	221	10.83 (275)	12.56 (319)	4.13 (105)	0.41 (10.5)	6.89 (175)	R 5/8	0.26 (6.5)	6.02 (153)	6.26 (159)	4.04 (102.5)	0.98 (25)	1.26 (32)	7.09 (180)	4.84 (123)	7.05 (179)
DMX 7-16	221	10.83 (275)	12.56 (319)	4.13 (105)	0.41 (10.5)	6.89 (175)	R 5/8	0.26 (6.5)	6.02 (153)	6.26 (159)	4.04 (102.5)	0.98 (25)	1.26 (32)	7.09 (180)	4.84 (123)	7.05 (179)
DMX 8-10	221	10.83 (275)	12.56 (319)	4.13 (105)	0.41 (10.5)	6.89 (175)	R 5/8	0.26 (6.5)	6.02 (153)	6.26 (159)	4.04 (102.5)	0.98 (25)	1.26 (32)	7.09 (180)	4.84 (123)	7.05 (179)
DMX 9-10	221	10.83 (275)	12.56 (319)	4.13 (105)	0.41 (10.5)	6.89 (175)	R 5/8	0.26 (6.5)	6.02 (153)	6.26 (159)	4.04 (102.5)	0.98 (25)	1.26 (32)	7.09 (180)	4.84 (123)	7.05 (179)
DMX 12-10	221	10.83 (275)	12.56 (319)	4.13 (105)	0.41 (10.5)	6.89 (175)	R 5/8	0.26 (6.5)	6.02 (153)	6.26 (159)	4.04 (102.5)	0.98 (25)	1.26 (32)	7.09 (180)	4.84 (123)	7.05 (179)
DMX 14-16	221	10.83 (275)	12.56 (319)	4.13 (105)	0.41 (10.5)	6.89 (175)	R 5/8	0.26 (6.5)	6.02 (153)	6.26 (159)	4.04 (102.5)	0.98 (25)	1.26 (32)	7.09 (180)	4.84 (123)	7.05 (179)
DMX 14-10	221	10.83 (275)	12.56 (319)	4.13 (105)	0.41 (10.5)	6.89 (175)	R 5/8	0.26 (6.5)	6.02 (153)	6.26 (159)	4.04 (102.5)	0.98 (25)	1.26 (32)	7.09 (180)	4.84 (123)	7.05 (179)
DMX 16-10	221	10.83 (275)	12.56 (319)	4.13 (105)	0.41 (10.5)	6.89 (175)	R 5/8	0.26 (6.5)	6.02 (153)	6.26 (159)	4.04 (102.5)	0.98 (25)	1.26 (32)	7.09 (180)	4.84 (123)	7.05 (179)
DMX 17-4	221	12.72 (323)	12.56 (319)	4.13 (105)	0.41 (10.5)	6.89 (175)	R 1 1/4	0.26 (6.5)	6.97 (177)	6.26 (159)	4.04 (102.5)	1.5 (38)	2.52 (64)	7.09 (180)	4.84 (123)	7.56 (192)
DMX 18-10	221	10.83 (275)	12.56 (319)	4.13 (105)	0.41 (10.5)	6.89 (175)	R 5/8	0.26 (6.5)	6.02 (153)	6.26 (159)	4.04 (102.5)	0.98 (25)	1.26 (32)	7.09 (180)	4.84 (123)	7.05 (179)
DMX 25-3	221	12.99 (330)	12.56 (319)	4.13 (105)	0.41 (10.5)	6.89 (175)	R 1 1/4	0.26 (6.5)	7.4 (188)	6.26 (159)	4.04 (102.5)	1.57 (40)	3.15 (80)	7.09 (180)	4.84 (123)	7.76 (197)
DMX 26-10	221	10.83 (275)	12.56 (319)	4.13 (105)	0.41 (10.5)	6.89 (175)	R 5/8	0.26 (6.5)	6.02 (153)	6.26 (159)	4.04 (102.5)	0.98 (25)	1.26 (32)	7.09 (180)	4.84 (123)	7.05 (179)
DMX 27-10	221	10.83 (275)	12.56 (319)	4.13 (105)	0.41 (10.5)	6.89 (175)	R 5/8	0.26 (6.5)	6.02 (153)	6.26 (159)	4.04 (102.5)	0.98 (25)	1.26 (32)	7.09 (180)	4.84 (123)	7.05 (179)
DMX 35-10	221	10.83 (275)	12.56 (319)	4.13 (105)	0.41 (10.5)	6.89 (175)	R 5/8	0.26 (6.5)	6.02 (153)	6.26 (159)	4.04 (102.5)	0.98 (25)	1.26 (32)	7.09 (180)	4.84 (123)	7.05 (179)
DMX 39-4	221	12.72 (323)	12.56 (319)	4.13 (105)	0.41 (10.5)	6.89 (175)	R 1 1/4	0.26 (6.5)	6.97 (177)	6.26 (159)	4.04 (102.5)	1.5 (38)	2.52 (64)	7.09 (180)	4.84 (123)	7.56 (192)
DMX 50-10	221	10.83 (275)	12.56 (319)	4.13 (105)	0.41 (10.5)	6.89 (175)	R 5/8	0.26 (6.5)	6.02 (153)	6.26 (159)	4.04 (102.5)	0.98 (25)	1.26 (32)	7.09 (180)	4.84 (123)	7.05 (179)
DMX 60-3	221	12.99 (330)	12.56 (319)	4.13 (105)	0.41 (10.5)	6.89 (175)	R 1 1/4	0.26 (6.5)	7.4 (188)	6.26 (159)	4.04 (102.5)	1.57 (40)	3.15 (80)	7.09 (180)	4.84 (123)	7.76 (197)
DMX 75-4	221	12.72 (323)	12.56 (319)	4.13 (105)	0.41 (10.5)	6.89 (175)	R 1 1/4	0.26 (6.5)	6.97 (177)	6.26 (159)	4.04 (102.5)	1.5 (38)	2.52 (64)	7.09 (180)	4.84 (123)	7.56 (192)
DMX 115-3	221	12.99 (330)	12.56 (319)	4.13 (105)	0.41 (10.5)	6.89 (175)	R 1 1/4	0.26 (6.5)	7.4 (188)	6.26 (159)	4.04 (102.5)	1.57 (40)	3.15 (80)	7.09 (180)	4.84 (123)	7.76 (197)

Dimensions, DMX model 226

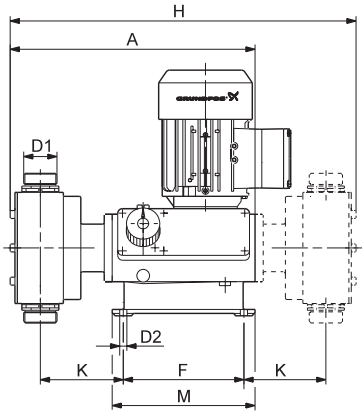

Dimensions, DMX model 226, version M

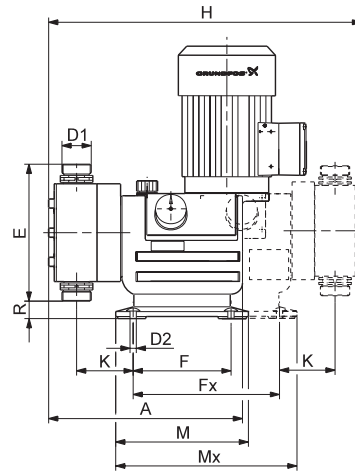
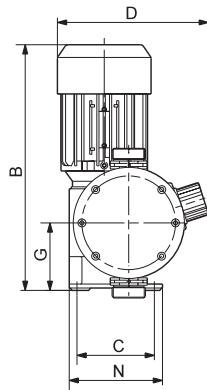

Fig. 25 Dimensions, DMX model 226, version L

TMM3 2086 3605

Dimensions in inches (mm)

Pump	Model	Version	A	B	C	D	D1	D2	E	F	Fx	G	H	K	M	Mx	N	R
DMX 52-8	226	M	11.89 (302)	12.2 (310)	3.84 (97.5)	7.48 (190)	G 1 1/4	0.35 (9)	7.01 (178)	5.98 (152)	-	3.37 (85.5)	16.73 (425)	4.11 (104.5)	7.09 (180)	7.09 (180)	4.65 (118)	0.16 (4)
DMX 67-10	226	L	14.41 (366)	14.65 (372)	5.35 (136)	8.74 (222)	G 1 1/4	0.35 (9)	7.01 (178)	5.51 (140)	8.19 (208)	4.84 (123)	17.32 (440)	3.15 (80)	7.48 (190)	10.16 (258)	6.3 (160)	1.34 (34)
DMX 82-5	226	M	11.89 (302)	12.2 (310)	3.84 (97.5)	7.48 (190)	G 1 1/4	0.35 (9)	7.01 (178)	5.98 (152)	-	3.37 (85.5)	16.73 (425)	4.11 (104.5)	7.09 (180)	7.09 (180)	4.65 (118)	0.16 (4)
DMX 95-8	226	L	14.41 (366)	14.65 (372)	5.35 (136)	8.74 (222)	G 1 1/4	0.35 (9)	7.4 (188)	5.51 (140)	8.19 (208)	4.84 (123)	17.48 (444)	3.15 (80)	7.48 (190)	10.16 (258)	6.3 (160)	1.14 (29)
DMX 100-8	226	M	11.89 (302)	12.2 (310)	3.84 (97.5)	7.48 (190)	G 1 1/4	0.35 (9)	7.01 (178)	5.98 (152)	-	3.37 (85.5)	16.73 (425)	4.11 (104.5)	7.09 (180)	7.09 (180)	4.65 (118)	0.16 (4)
DMX 130-3	226	M	11.89 (302)	12.2 (310)	3.84 (97.5)	7.48 (190)	G 1 1/4	0.35 (9)	7.01 (178)	5.98 (152)	-	3.37 (85.5)	16.73 (425)	4.11 (104.5)	7.09 (180)	7.09 (180)	4.65 (118)	0.16 (4)
DMX 132-10	226	L	14.41 (366)	14.65 (372)	5.35 (136)	8.74 (222)	G 1 1/4	0.35 (9)	7.01 (178)	5.51 (140)	8.19 (208)	4.84 (123)	17.32 (440)	3.15 (80)	7.48 (190)	10.16 (258)	6.3 (160)	1.34 (34)
DMX 152-6	226	L	-	14.65 (372)	5.35 (136)	8.74 (222)	G 1 1/4	0.35 (9)	8.19 (208)	5.51 (140)	8.19 (208)	4.84 (123)	17.83 (453)	3.27 (83)	7.48 (190)	10.16 (258)	6.3 (160)	0.75 (19)
DMX 160-5	226	M	11.89 (302)	12.2 (310)	3.84 (97.5)	7.48 (190)	G 1 1/4	0.35 (9)	7.01 (178)	5.98 (152)	-	3.37 (85.5)	16.73 (425)	4.11 (104.5)	7.09 (180)	7.09 (180)	4.65 (118)	0.16 (4)
DMX 199-8	226	L	14.41 (366)	14.65 (372)	5.35 (136)	8.74 (222)	G 1 1/4	0.35 (9)	7.4 (188)	5.51 (140)	8.19 (208)	4.84 (123)	17.48 (444)	3.15 (80)	7.48 (190)	10.16 (258)	6.3 (160)	1.14 (29)
DMX 249-3	226	L	-	15.35 (390)	5.35 (136)	8.74 (222)	G 2	0.35 (9)	9.45 (240)	5.51 (140)	8.19 (208)	4.84 (123)	19.61 (498)	3.62 (92)	7.48 (190)	-	6.3 (160)	0.12 (3)
DMX 255-3	226	M	11.89 (302)	12.2 (310)	3.84 (97.5)	7.48 (190)	G 1 1/4	0.35 (9)	7.01 (178)	5.98 (152)	-	3.37 (85.5)	16.73 (425)	4.11 (104.5)	7.09 (180)	7.09 (180)	4.65 (118)	0.16 (4)
DMX 321-6	226	L	-	14.65 (372)	5.35 (136)	8.74 (222)	G 1 1/4	0.35 (9)	8.19 (208)	5.51 (140)	8.19 (208)	4.84 (123)	17.83 (453)	3.27 (83)	7.48 (190)	10.16 (258)	6.3 (160)	0.75 (19)
DMX 525-3	226	L	-	15.35 (390)	5.35 (136)	8.74 (222)	G 2	0.35 (9)	9.45 (240)	5.51 (140)	8.19 (208)	4.84 (123)	19.61 (498)	3.62 (92)	7.48 (190)	-	6.3 (160)	0.12 (3)

Performance data, DMX model 221

Pump	Model	Vstroke [cm ³]	60 Hz			Motor power	
			Capacity ¹⁾ [GPH (l/hr)]	Max. pressure ²⁾ [psi (bar)]	Stroke rate [n/min]	Standard [kW]	PTC ³⁾ [kW]
DMX 4-10	221	2.2	1.3 (5)	145 (10)	35	0.09	0.09
DMX 7-10	221	3.8	2.1 (8)	145 (10)	35	0.09	0.09
DMX 7-16*	221	1.9	2.6 (10)	232 (16)	75	0.09	0.18
DMX 8-10	221	2.2	2.6 (10)	145 (10)	75	0.09	0.09
DMX 9-10	221	4.9	2.9 (11)	145 (10)	35	0.09	0.09
DMX 12-10	221	6.9	3.7 (14)	145 (10)	35	0.09	0.18
DMX 14-16*	221	1.9	5.0 (19)	232 (16)	144	0.09	0.18
DMX 14-10	221	3.8	4.5 (17)	145 (10)	75	0.09	0.09
DMX 16-10	221	2.2	5.0 (19)	145 (10)	144	0.09	-
DMX 17-4	221	10.4	5.3 (20)	58 (4)	35	0.09	0.18
DMX 18-10	221	4.9	5.8 (22)	145 (10)	75	0.09	0.09
DMX 25-3	221	16.0	8.5 (32)	44 (3)	35	0.09	0.18
DMX 26-10	221	6.9	8.2 (31)	145 (10)	75	0.09	0.18
DMX 27-10	221	3.8	8.5 (32)	145 (10)	144	0.09	-
DMX 35-10	221	4.9	11.1 (42)	145 (10)	144	0.09	-
DMX 39-4	221	10.4	12.4 (47)	58 (4)	75	0.09	0.18
DMX 50-10	221	6.9	15.9 (60)	116 (8)	144	0.09	-
DMX 60-3	221	16.0	19.0 (72)	44 (3)	75	0.09	0.18
DMX 75-4	221	10.4	23.8 (90)	51 (3.5)	144	0.09	-
DMX 115-3	221	16.0	36.5 (138)	36 (2.5)	144	0.09	-

1) The maximum flow is measured at maximum back pressure.

2) Maximum back pressure.

3) Motor for frequency control.

*) Operation at a back pressure of 232 psi reduces diaphragm life.

The values in the table above are based on the following conditions:

- dosing liquid: water
- flooded suction: 1.6 ft.
- fully vented dosing head
- 400 V motor, 3-phase.

Minimum back pressure: 14.5 psi.

The back pressure refers to the pressure at the pump discharge valve. Pressure losses in the line to the injection point are not taken into account.

Performance data, DMX model 226

Pump	Model	Vstroke [cm ³]	60 Hz				Motor power		If delivered without motor
			Capacity ^{1) 2)} [GPH (l/hr)]	Max. pressure ³⁾ 3-phase [psi (bar)]	Max. pressure ³⁾ 1-phase [psi (bar)]	Stroke rate [n/min]	Standard [kW]	PTC ⁴⁾ [kW]	Recommended motor power [hp]
DMX 52-8	226	13.8	16.4 (62)	116 (8)	116 (8)	75.6	0.18	-	0.25
DMX 67-10	226	18.5	21.1 (80)	145 (10)	145 (10)	68.4	0.37	0.55	0.5
DMX 82-5	226	22.0	25.9 (98)	73 (5)	73 (5)	75.6	0.18	-	0.25
DMX 95-8	226	27.8	30.1 (114)	116 (8)	116 (8)	68.4	0.37	0.55	0.5
DMX 100-8	226	13.8	31.7 (120)	116 (8)	116 (8)	144	0.18	-	0.25
DMX 130-3	226	36.0	41.2 (156)	44 (3)	44 (3)	75.6	0.18	-	0.25
DMX 132-10	226	18.5	41.7 (158)	145 (10)	145 (10)	144	0.37	0.55	0.5
DMX 152-6	226	44.6	48.1 (182)	87 (6)	87 (6)	68.4	0.37	0.55	0.5
DMX 160-5	226	22.0	50.7 (192)	73 (5)	73 (5)	144	0.18	-	0.25
DMX 199-8	226	27.8	63.1 (239)	116 (8)	116 (8)	144	0.37	0.55	0.5
DMX 249-3	226	73.0	79.0 (299)	44 (3)	44 (3)	68.4	0.37	0.55	0.5
DMX 255-3	226	36.0	80.8 (306)	44 (3)	44 (3)	144	0.18	-	0.25
DMX 321-6	226	44.6	101.7 (385)	87 (6)	58 (4)	144	0.37	0.55	0.5
DMX 525-3	226	73.0	166.4 (630)	44 (3)	44 (3)	144	0.37	0.55	0.5

1) The maximum flow is measured at maximum back pressure.

2) The capacity is per dosing head.

(Twin-head pumps have double the flow rate of single-head versions.)

3) Maximum back pressure.

4) Motor for frequency control.

The values in the table above are based on the following conditions:

- maximum back pressure
- dosing liquid: water
- flooded suction: 1.6 ft.
- fully vented dosing head
- 400 V, 3-phase motor.

Suction lift, DMX model 221

Pump	Model	Liquids with a viscosity similar to water			Liquids with max. permissible viscosity	
		Suction lift - 60 Hz		Max. length of suction line [ft]	Max. permissible viscosity ⁴⁾ [cps]	Suction lift [ft]
		Continuous operation ¹⁾ [ft]	Start-up ²⁾ [ft]			
DMX 4-10	221	13.1	13.1	16.4	400	3.3
DMX 7-10	221	13.1	13.1	16.4	400	3.3
DMX 7-16*	221	13.1	13.1	16.4	400	3.3
DMX 8-10	221	13.1	13.1	16.4	400	3.3
DMX 9-10	221	9.8	13.1	13.1	200	3.3
DMX 12-10	221	9.8	13.1	13.1	200	3.3
DMX 14-16*	221	11.5	11.5	16.4	200	3.3
DMX 14-10	221	13.1	13.1	16.4	400	3.3
DMX 16-10	221	11.5	11.5	16.4	200	3.3
DMX 17-4	221	3.3	9.8	6.6	200	3.3 ³⁾
DMX 18-10	221	9.8	13.1	13.1	200	3.3
DMX 25-3	221	3.3	3.3	6.6	200	3.3 ³⁾
DMX 26-10	221	9.8	13.1	13.1	200	3.3 ³⁾
DMX 27-10	221	11.5	11.5	16.4	200	3.3
DMX 35-10	221	8.2	11.5	13.1	100	3.3
DMX 39-4	221	3.3	9.8	6.6	100	3.3
DMX 50-10	221	8.2	11.5	13.1	100	3.3
DMX 60-3	221	3.3	3.3	6.6	100	3.3
DMX 75-4	221	1.6	8.2	6.6	100	3.3 ³⁾
DMX 115-3	221	1.6	3.3	6.6	100	3.3 ³⁾

1) Suction line and dosing head filled (continuous operation).

2) Suction line and dosing head not filled, but dosing head and valves moistened (commissioning).

3) Flooded suction.

*) Operation at a back pressure of 232 psi reduces diaphragm life.

The values in the table above are based on the following conditions:

Liquids with a viscosity similar to water:

- back pressure: 22 to 44 psi
- non-degassing and non-abrasive liquids
- temperature: 68 °F
- stroke length: 100%.

Liquids with max. permissible viscosity:

- newtonian liquids
- non-degassing and non-abrasive liquids
- temperature: 68 °F
- standard pump version.

Suction lift, DMX model 226

Pump	Model	Liquids with a viscosity similar to water			Liquids with max. permissible viscosity	
		Suction lift - 60 Hz		Max. length of suction line [ft]	Max. permissible viscosity ³⁾ [cps]	Suction lift [ft]
		Continuous operation ¹⁾ [ft]	Start-up ²⁾ [ft]			
DMX 52-8	226	8.2	3.3	13.1	700	3.3
DMX 67-10	226	8.2	3.3	13.1	700	3.3
DMX 82-5	226	8.2	3.3	9.8	500	3.3
DMX 95-8	226	8.2	3.3	9.8	500	3.3
DMX 100-8	226	8.2	3.3	13.1	400	3.3
DMX 130-3	226	6.6	3.3	9.8	400	0
DMX 132-10	226	8.2	3.3	13.1	400	3.3
DMX 152-6	226	6.6	3.3	9.8	400	0
DMX 160-5	226	8.2	3.3	9.8	200	0
DMX 199-8	226	8.2	3.3	9.8	200	0
DMX 249-3	226	3.3	1.6	6.6	100	0
DMX 255-3	226	6.6	3.3	9.8	100	0
DMX 321-6	226	6.6	3.3	9.8	100	0
DMX 525-3	226	3.3	1.6	6.6	50	0

1) Suction line and dosing head filled (continuous operation).

2) Suction line and dosing head not filled, but dosing head and valves moistened (commissioning).

3) Greater viscosity may be available with special check valve configuration.

The values in the table above are based on the following conditions:

Liquids with a viscosity similar to water:

- back pressure: 22 to 44 psi
- non-degassing and non-abrasive liquids
- temperature: 68 °F
- stroke length: 100%
- standard pump version.

Liquids with max. permissible viscosity:

- newtonian liquids
- non-degassing and non-abrasive liquids
- temperature: 68 °F
- standard pump version.

Weights, DMX model 221

Pump	Weights [lbs]	
	PVC, PP, PVDF	Stainless steel
DMX 4-10	11	15.4
DMX 7-10	11	15.4
DMX 7-16	11	15.4
DMX 8-10	11	15.4
DMX 9-10	11	15.4
DMX 12-10	11	15.4
DMX 14-16	11	15.4
DMX 14-10	11	15.4
DMX 16-10	11	15.4
DMX 17-4	16.5	26.5
DMX 18-10	11	15.4
DMX 25-3	17.6	28.7
DMX 26-10	11	15.4
DMX 27-10	11	15.4
DMX 35-10	11	15.4
DMX 39-4	16.5	26.5
DMX 50-10	11	15.4
DMX 60-3	17.6	28.7
DMX 75-4	16.5	26.5
DMX 115-3	17.6	28.7

The weights are approximate.

Weights, DMX model 226

Pump	Weights [lbs]			
	Simplex pump		Duplex pump	
	PVC, PP, PVDF	Stainless steel	PVC, PP, PVDF	Stainless steel
DMX 52-8	33	46	53	79
DMX 67-10	46	66	66	106
DMX 82-5	33	46	53	79
DMX 95-8	46	66	66	106
DMX 100-8	33	46	53	79
DMX 130-3	33	46	53	79
DMX 132-10	46	66	66	106
DMX 152-6	46	66	66	106
DMX 160-5	33	46	53	79
DMX 199-8	46	66	66	106
DMX 249-3	46	66	66	106
DMX 255-3	33	46	53	79
DMX 321-6	46	66	66	106
DMX 525-3	46	66	66	106

The weights are approximate.

Sound pressure

Pump range	Sound pressure level * [dB(A)]
DMX model 221	55
DMX model 226	55

*) Tested according to DIN 45635-01-KL3.

Accuracy

Pump	Dosing flow fluctuation	Linearity deviation
DMX	< ±1.5% within the 10 to 100% control range	<ul style="list-style-type: none"> • ±4% of full-scale value within the 20 to 100% control range; • direction of adjustment from maximum to minimum stroke length.

The values in the table above are based on the following conditions:

- dosing liquid: water
- fully vented dosing head
- standard version of pump.

Permissible temperatures of dosing liquid

Dosing head material	Permissible temperatures of dosing liquid	
	DMX	
	p < 145 psi [°F]	p < 232 psi [°F]
PVC	32 to 104	32 to 68
Stainless steel, 316Ti *	14 to 158	14 to 158
Polypropylene (PP)	32 to 104	-
PVDF	14 to 140 (158 °F at 130 psi)	14 to 68

*) For SIP/CIP applications, a temperature of 293 °F is permissible for a short time (approx. 15 min.) at p < 29 psi.
(CIP = Cleaning-In-Place).
(SIP = Sterilisation/Steaming-In-Place).

DMX selection (1.3 to 2 x 166 GPH)

The example in bold is a: **DMX 4-10 B PV/T/T-X-H1SSB**

Max. capacity and pressure	Control variant	Materials of dosing head, gaskets and valve balls	Control panel position	Motor voltage	Valve type	Connection, suction/discharge	Mains plug
[l/h] - [bar]	B = No controls	Dosing head version: PP= Polypropylene PV= PVDF PVC=Polyvinyl chloride SS= Stainless steel 316	Control panel position X = No panel S = Side-mounted W = Wall-mounted	Motor voltage H = 1 x 120 V, 50/60 Hz F = Without motor, Nema flange.(US) Nema 42C for DMX 221 Nema 56C for DMX 226	1 = Standard 3 = Spring-loaded, 0.7 psi suction, 11.6 psi discharge 4 = Spring-loaded, discharge side only 5 = Valves for abrasive liquids	S = Tube 0.375" / 0.5" V = Threaded NPT 1/4" A9= Threaded NPT 1/2" male A3 = Threaded NPT 3/4" A7 = Threaded NPT 3/4" male A4 = Threaded NPT 1 1/4" A8 = Threaded NPT 1 1/4" male	B = USA and CAN, 120 V X = No plug
	AR= Etron Profi (analog/pulse control)	PV-R, PVC-R = Integrated relief valve PP-L, PV-L. PVC-L, SS-L = Integrated diaphragm leakage detection PV-RL, PVC-RL = Integrated relief valve and diaphragm leakage detection	Gasket material: E = EPDM V = FKM (fluorocarbon) T = PTFE			Valve type	
	AT5= Servomotor 1 x 115 V, 50/60 Hz, 4-20 mA	Valve ball material: C = Ceramic G = Glass T = PTFE SS= Stainless steel 316					

Size	Control variant	Materials of dosing head, gaskets and valve balls	Control panel position	Motor voltage	Valve type	Connection, suction / discharge	Mains plug
DMX 221, DN8							
4-10	B AR AT5	PP/E/C	X S W	H	1 3 4 5	S (PVC, PP) A9 (PVDF is optional on PVC dosing heads)	B X
7-10		PP/E/SS					
7-16		PP/E/T					
8-10		PP/V/C					
9-10		PP/V/G					
12-10		PP/V/T					
14-16		PV/T/C					
14-10		PV/T/T					
16-10		PV/V/T					
18-10		PVC/E/C					
26-10		PVC/E/SS					
27-10		PVC/E/T					
35-10		PVC/T/C					
50-10	PVC/T/T						
	PVC/V/C						
	PVC/V/G						
	PVC/V/SS						
	SS/T/SS	X	H	1	A9	B	
	SS/V/SS	S	H	3	V	X	
		W		4			
DMX 221, DN20							
17-4	B AR AT5	PP/E/SS	X S W	H	1 3 4	A7 (PVDF, PVC)	B X
25-3		PP/E/T					
39-4		PP/T/T					
60-3		PP/V/G					
75-4		PTFE/T/C					
115-3		PV/T/T					
		PVC/E/SS					
		PVC/E/T					
		PVC/T/C					
		PVC/V/C					
	PVC/V/G						
	PVC/V/SS						
	SS/T/SS	X	H	1	A3	B	
	SS/V/SS	S	H	3		X	
		W		4			
DMX 226, DN20							

Pump selection

DMX

Max. capacity and pressure	Control variant	Materials of dosing head, gaskets and valve balls	Control panel position	Motor voltage	Valve type	Connection, suction/discharge	Mains plug
[l/h] - [bar]	B = No controls	Dosing head version: PP= Polypropylene PV= PVDF PVC=Polyvinyl chloride SS= Stainless steel 316	Control panel position X = No panel S = Side-mounted W = Wall-mounted	Motor voltage H = 1 x 120 V, 50/60 Hz F = Without motor, Nema flange.(US) Nema 42C for DMX 221 Nema 56C for DMX 226		S = Tube 0.375" / 0.5" V = Threaded NPT 1/4" A9 = Threaded NPT 1/2" male A3 = Threaded NPT 3/4" A7 = Threaded NPT 3/4" male A4 = Threaded NPT 1 1/4" A8 = Threaded NPT 1 1/4" male	B = USA and CAN, 120 V X = No plug
	AR= Etron Profi (analog/pulse control)						
	AT5= Servomotor 1 x 115 V, 50/60 Hz, 4-20 mA						
		Gasket material: E = EPDM V = FKM (fluorocarbon) T = PTFE					
		Valve ball material: C = Ceramic G = Glass T = PTFE SS= Stainless steel 316					
			Valve type 1 = Standard 3 = Spring-loaded, 0.7 psi suction, 11.6 psi discharge 4 = Spring-loaded, discharge side only 5 = Valves for abrasive liquids				

Size	Control variant	Materials of dosing head, gaskets and valve balls	Control panel position	Motor voltage	Valve type	Connection, suction / discharge	Mains plug
52-8	B AR AT5	PP/E/SS	X S W	H F	1 3 4	A7 (PVDF, PVC)	B X
67-10		PP/E/T					
82-5		PP/T/T					
95-8		PP/V/G					
100-8		PV/T/T					
130-3		PV/V/T					
132-10		PVC/E/SS					
152-6		PVC/E/T					
160-5		PVC/T/C					
199-8		PVC/V/C					
255-3		PVC/V/G					
321-6		PVC/V/SS					
		SS/T/SS					
	SS/V/SS	S	F	3			
		W		4			

DMX 226, DN32

249-3	B AR AT5	PP/E/T	X S W	H F	1 3 4	A8 (PVDF, PVC)	B X
525-3		PP/V/G					
		PV/T/T					
		PVC/E/SS					
		PVC/V/G					
		SS/E/SS					
	SS/T/SS	S	F	3			
	SS/V/SS	W		4			

Note:

Mains plug only for single-phase pumps.

DMX model 226 is available with two dosing heads.

Type key example: DMX 160-5/160-5 B PP/V/G-X-F1A7A7X.

List of pumped liquids

This resistance table is intended to serve as a general guide only for material resistance (at room temperature) and is not a substitute for actual testing of the chemicals and pump materials under specific working conditions.

The data shown is based upon information from various sources available, but be aware that many factors, such as purity, temperature, abrasive particles, etc. can affect the chemical resistance of a given material.

Note: Some of the liquids in this table may be toxic, corrosive or hazardous.

Note: Be careful when handling these liquids.

Pumped liquid (68°F)		Concentration %	Materials									
Designation	Chemical formula		Pump housing				Gasket			Ball		
			PP	PVDF	Stainless steel, 316	PVC	FKM	EPDM	PTFE	Centellen C	Ceramic	Glass
Acetic acid	CH ₃ COOH	25	●	●	●	●	—	○	●	○	●	●
		60	●	●	●	●	●	○	●	○	●	●
		85	●	●	●	—	—	—	●	○	●	●
Aluminium chloride	AlCl ₃	40	●	●	—	●	●	●	●	●	●	
Aluminium sulphate	Al ₂ (SO ₄) ₃	60	●	●	●	●	●	●	●	●	—	
Ammonia, aqueous	NH ₄ OH	28	●	●	●	—	—	●	●	○	●	—
Calcium hydroxide★ ⁵	Ca(OH) ₂		●	●	●	●	●	●	●	●	●	●
Calcium hypochlorite	Ca(OCl) ₂	20	○	●	—	●	●	●	●	●	●	●
		10	●	●	●	●	●	●	●	●	●	●
		30	—	●	—	●	●	○	●	○	●	●
Chromic acid★ ³	H ₂ CrO ₄	40	—	●	—	●	●	—	●	○	●	●
		50	—	●	—	●	●	—	●	○	●	●
Copper sulphate	CuSO ₄	30	●	●	●	●	●	●	●	●	●	●
Ferric chloride★ ¹	FeCl ₃	100	●	●	—	●	●	●	●	●	●	●
Ferric sulphate★ ¹	Fe ₂ (SO ₄) ₃	100	●	●	●	●	●	●	●	●	●	●
Ferrous chloride	FeCl ₂	100	●	●	—	●	●	●	●	●	●	●
Ferrous sulphate	FeSO ₄	50	●	●	●	●	●	●	●	●	●	●
Hydrochloric acid	HCl	<25	●	●	—	●	○	●	●	●	●	●
		25 to 37	●	●	—	●	—	●	●	○	●	●
Hydrogen peroxide	H ₂ O ₂	30	●	●	●	●	●	●	●	●	●	●
		10	●	●	●	●	●	●	●	●	●	●
		30	●	●	●	●	●	●	●	—	●	●
Nitric acid	HNO ₃	40	○	●	●	●	●	●	●	—	●	●
		70	—	●	●	—	●	—	●	—	●	●
		5	●	●	—	●	—	●	●	—	●	●
Peracetic acid	CH ₃ COOOH	5	●	●	—	●	—	●	●	—	●	●
Potassium hydroxide	KOH	50	●	—	●	●	—	●	●	○	●	—
Potassium permanganate	KMnO ₄	10	●	●	●	●	—	●	●	●	●	●
Sodium chlorate	NaClO ₃	30	●	●	●	●	○	●	●	●	●	●
Sodium chloride	NaCl	30	●	●	—	●	●	●	●	●	●	●
Sodium chlorite	NaClO ₂	20	●	○	—	—	●	●	●	●	●	●
		20	●	○	●	●	●	●	●	○	●	—
		30	●	—	●	●	●	●	●	○	●	—
Sodium hydroxide	NaOH	30	●	—	●	●	●	●	●	○	●	—
Sodium hypochlorite	NaOCl	20	○	●	—	●	●	●	●	●	●	●
Sodium sulphide	Na ₂ S	30	●	●	●	●	●	●	●	●	●	—
Sodium sulphite★ ⁴	Na ₂ SO ₃	20	●	●	●	●	●	●	●	●	●	—
Sulphurous acid	H ₂ SO ₃	6	●	●	●	●	●	●	●	●	●	○
Sulphuric acid★ ²	H ₂ SO ₄	<80	●	●	—	○	●	○	●	○	●	○
		80 to 98	○	●	—	—	●	—	●	●	●	—

● Resistant. ★¹ Risk of crystallisation.
 ○ Limited resistance. ★² Reacts violently with water and generates much heat. (Pump should be absolutely dry before dosing sulphuric acid.)
 — Not resistant. ★³ Must be fluoride-free when glass balls are used.
 ★⁴ In neutral solutions.
 ★⁵ Saturated solution 0.1%.

96658092 1206	US

Subject to alterations.

GRUNDFOS Pumps Corporation
17100 West 118th Terrace
Olathe, Kansas 66061
Phone: +1-913-227-3400
Telefax: +1-913-227-3500

GRUNDFOS Canada Inc.
2941 Brighton Road
Oakville, Ontario L6H 6C9 Canada
Phone: +1-905 829 9533
Telefax: +1-905 829 9512

Bombas GRUNDFOS de Mexico S.A. de C.V.
Boulevard TLC No. 15
Parque Industrial Stiva Aeropuerto
Apodaca, N.L. Mexico 66600
Phone: +52-81-8144 4000
Telefax: +52-81-8144 4010